

## Optional card relay for Control Unit **BMS16** Rev. 1

The **CARD-BMS16** is an electronic conversion card *CURRENT-VOLTAGE*, it's can be coupled to the control unit BX308xp and BX316xp  
Inserting the into the connector it allows to convert the current generated by the probe in voltage.

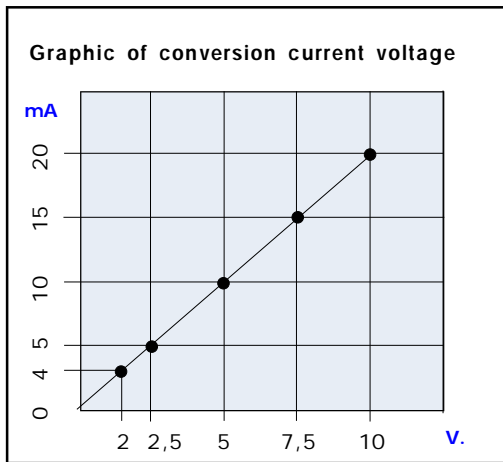

**Installation  
and user guide**

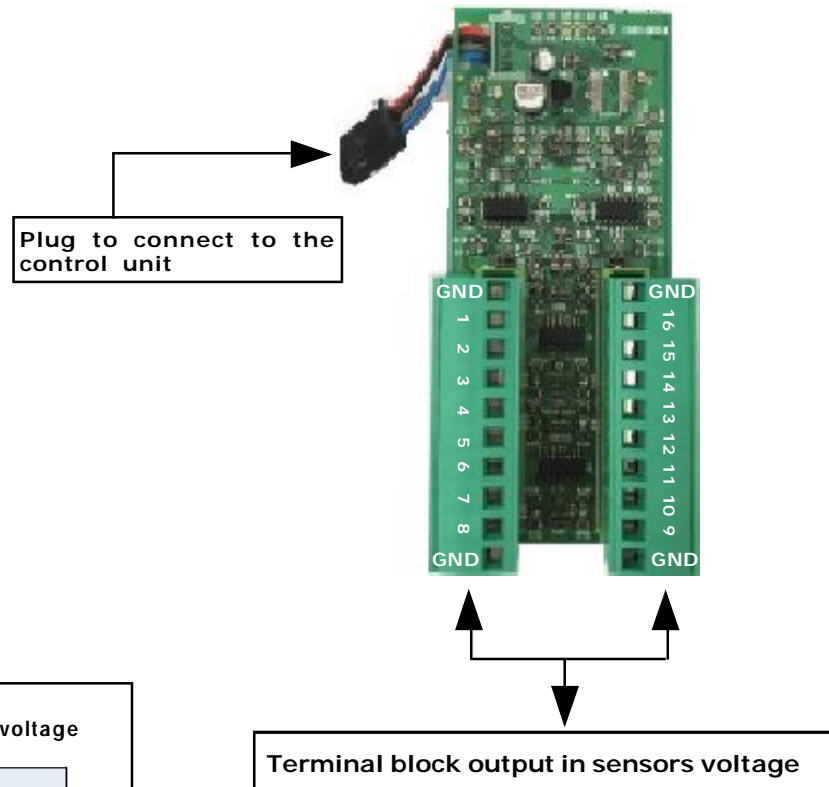

**INSTALL IN SAFE  
AREA, NO ATEX**

**CONFORMITY**

**EN 50194  
EN 50270**

### Important Note

Before connecting the unit careful reading of instruction booklet is recommended, and it is kept in a safe place for future reference.

Furthermore, the correct electrical connections according to the enclosed drawings, complying with instructions and regulations in force, is recommended.

Electric connections also available on

Channel: Beinat gas solutions



**INSURANCE.** This device is insured by the SOCIETÀ REALE MUTUA for the PRODUCT'S GENERAL LIABILITY up to a maximum of 1,500,000.00 EURO against damages caused by the device in case of failures in functioning.

**WARRANTY.** The warranty term is 3 years from manufacturing date, in agreement with the following conditions. The components acknowledged as faulty will be replaced free of charge, excluding the replacement of plastic or aluminium cases, bags, packing, batteries and technical reports.

The device must arrive free of shipment charges to **BEINAT S.r.l.**

Defects caused by unauthorized personnel tampering, incorrect installation and negligence resulting from phenomena outside normal functioning shall be excluded from the warranty.

**BEINAT S.r.l.** is not liable for possible damage, direct or indirect, to people, animals, or things; from product faults and from its enforced suspension of use.



**DISPOSAL OF OLD ELECTRICAL & ELECTRONIC EQUIPMENT**

This symbol on the product or its packaging to indicates that this product shall not be treated as household waste. Instead, it shall be handed over to the applicable collection point for the recycling of electrical and electronic equipment, such as for example:

- sales points, in case you buy a new and similar product
- local collection points (waste collection center, local recycling center, etc...)

By ensuring this product is disposed of correctly, you will help prevent potential negative consequence for the environment and human health, which could otherwise be caused by inappropriate waste handing of this product. The recycling of materials will help to conserve natural resources. For more detailed information about recycling of this product, please contact your local city office, your household waste disposal service or the shop where you purchased the product.

**Attention:** in some countries of the European Union, the product is not included in the field of application of the National Law that applies the European Directive 2002/96/EC and therefore these countries have no obligation to carry out a separate collection at the "end of life" of the product.



Made in Italy

Card **CARD-BMS16**

*Lo styling è della b & b design*

Dealer stamp

Purchase date : .....

Serial number: .....

**Beinat S.r.l.** following the purpose of improving its products, it reserves the right to modify the technical, aesthetic and functional characteristics at any time and without giving any notice.

**BEINAT S.r.l.**  
 Via Fatebenefratelli 122/C 10077  
 S. Maurizio C/se (TO) - ITALY  
 Tel. 011.921.04.84 - Fax 011.921.14.77  
 http:// www.beinat.com



**Business** - info@beinat.com  
**Technical support** - laboratorio@beinat.com