

# Control Unit from 1 to 16 Conventional sensors BX316xp Rev.4

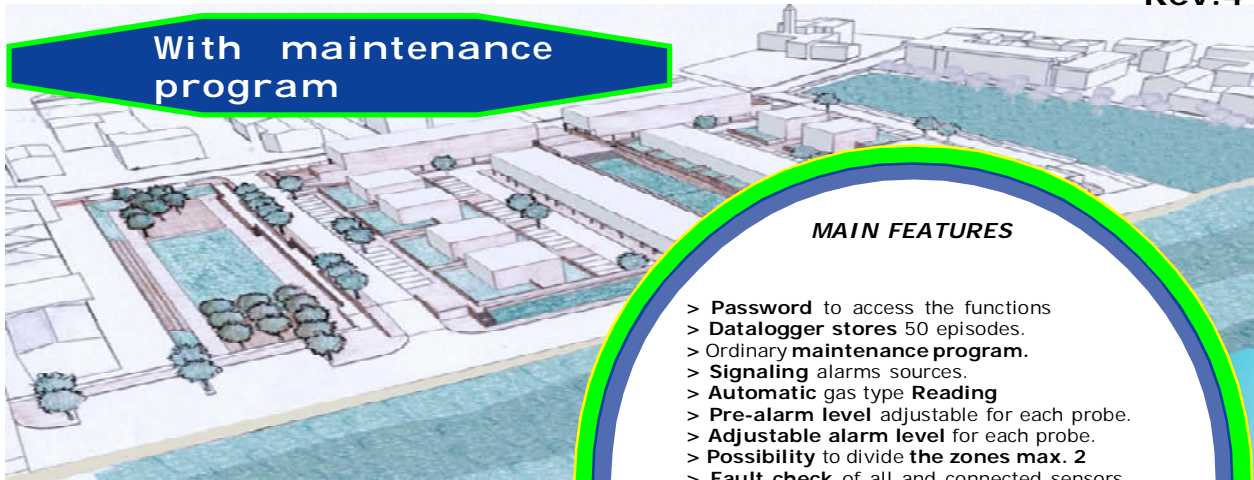

The experience and the knowledge acquired over the years within industrial sector and market together with the prestige that has always made BEINAT S.r.l. stand out from its competitors comes to the new Gas Control Unit "BX316xp" aimed at checking, by means of probes coupled to it, the presence of gas: **toxic, explosive, and Oxygen**. Cutting-edge technologies enable the Gas detection control unit to be installed in industrial environments and underground parking spaces. **Conventional sensors.**

Up to 16 remote probes from 4 to 20 mA can be connected in **conventional** mode for a single area or divided into two zones: 8 probes for every zone.

Gas concentration measured by every probe sequentially is shown directly on display, with a description of its origin.

The control unit features two levels of hazard:

**1st LEVEL, pre-alarm.** This data is variable. The technician can modify pre-alarm intervention for every probe according to the type of plant to be controlled.

The level can be selected from 3% to 16% of L.E.L. or from 45 to 240 ppm

**2nd LEVEL, general alarm.** it is set to 20 % of L.E.L. or 300ppm

The control unit is equipped with two general alarm relays with/without Positive Safety Switch to enable further independent control of two solenoid valves. Finally, the Control Unit allows the user to control the actual operation of the probes coupled.

**OXYGEN ALARM** for <Deficiency (Oxygen at 18.5%) and> Excess (Oxygen at 23.5%)  
**Expansion Cards**

**CARD-RLS4.** Relay card: each card has 4 relays, it can connect up to 16 cards

**CARD-BMS16.** Conversion card Current Voltage



**Important:** Assembly / maintenance of the appliance must be carried out by qualified personnel and in accordance with applicable laws and regulations.

The manufacturer assumes no responsibility for the use of products that have to comply with particular environmental and / or installation standards.



**Important note**

Before connecting the equipment, it is recommended that you read the instruction manual carefully and keep it for future reference. It is also recommended to perform the electrical connections correctly as per enclosed drawings, observing the instructions and the Standards.

**N.B. Refer to the documentation in all cases where the symbol is on the side**



**Installation and user guide**



**INSTALL IN SAFE AREA, NO ATEX**

**CONFORMITY**

EN 45544-1-3  
EN 50270  
EN 61010-1

Compliance EN 60079-29-1-2  
Reports issued by TUV Italia  
DM 01/02/1986





## Main specification

<b>Password :</b>	To access the settings menu
<b>Set:</b>	Date and time
<b>Select:</b>	The <b>sensors</b> to be enabled / disabled
<b>Select:</b>	The <b>Operating range</b> : 20% or 100 of <b>L.E.L.</b>
<b>Select:</b>	The <b>type of gas</b> that the probe must detect ( <b>Toxic, Explosive, Oxygen</b> )
<b>Set:</b>	The <b>Pre-Alarm level</b> , for every probe from 5% to 9%
<b>Set:</b>	The <b>Alarm level</b> , for every probe from 10% to 50%
<b>Select:</b>	The quantity of zones, " <b>1-2</b> " divisible 8 probes per zone
<b>Select:</b>	The operation of the relay " <b>pulsed or continuous</b> "
<b>Select:</b>	The function of <b>Positive Safety Switch</b>
<b>Select:</b>	The function of <b>saving</b> the alarm triggered
<b>Select:</b>	The exclusion or insertion of " <b>external siren</b> "
<b>Select:</b>	The exclusion or insertion of " <b>internal buzzer</b> " if an alarm is triggered
<b>Read:</b>	The <b>history of alarms (data logger)</b> , up to maximum 50 events
<b>Connection.</b>	Of a portable printer via USB port Relay expansion card; Voltage Current Conversion Card



**BX316xp**



**Optional cabinet**

### LCD display

Display:	Brand and <b>serial number</b>
Display:	Date and Time
Display:	the probe being monitored
Display:	automatic Explosive Gas and Operating range <b>L.E.L.</b> or Toxic Gas <b>ppm</b>
Display:	the chart of the amount of gas detected
Display:	<b>Warm up</b> on Display appears the " <b>count-down</b> " time

### Front Panel

**Navigation** buttons, **Test** Button for checking the control unit operation and **Reset** button for resetting alarm memories.  
LED that displays the silenced external siren. This operation can be performed by entering the Password  
Service LEDs: (see page 3)  
LED that displays the charge **status** of **Buffer battery**

## Technical specification

Main Power Supply <b>MODULE VERSION</b> .....	<b>12/15 VDC</b> ± 10%
Secondary power supply via battery <b>Max 2,2 Ah</b> (not supplied) .....	<b>12,7 VDC</b> ± 10%
Battery Charger <b>Max 2,2 Ah</b> .....	controlled
Max power demand to <b>15 VDC</b> .....	<b>25W Max @ 12 VDC</b>
Relay Contact Range .....	10A 250V resistive

### ALARMS

**Pre-Alarm** adjustable for every sensor from ..... 5% to 9% of LEL with 1% step  
**Main alarm** adjustable for every sensor from ..from 10% to 20% of LEL with 1% step (default 20% of LEL)  
**N.B. Entering the password (PUK)** is possible to adjust this alarm from 10% to 50%, step 5%  
ALARMS Oxygen ..... <Oxygen deficiency and > Oxygen excess See page 12

### INDICATIONS

Indication of mains power supplied, alarms, battery state, probe and battery over load, faults  
Manual alarm indication .....on display(BTN)  
Siren ON indication .....Indicated by Red LED  
Duration of warm up phase via count-down ..... 90 seconds  
Manual test ..... built-in  
External siren and internal Buzzer silencing ..... via software operation

### ALARM SENSORS ZONES

Number of Selectable zones ..... 2  
Number of connectable sensors ..... 16  
Sensor connection/disconnection .....through a special menu  
Connectable sensors ..... Semi-conductor, Catalytic, Electrochemical cell, Pellistore, Optical fluorescence  
Faults detected by failure circuit ..... Interruption , short circuit or failure  
Input signal ..... 4 ÷ 20 mA over 150 Ohm  
Operating Range only for explosive gases..... 0-20% or 0-100% of L.E.L.  
Data refresh ..... 2 ms  
Device Accuracy ..... 1% FS

### CONNECTIONS

Printer ..... through dedicated USB port  
**CARD-RLS4** Relay expansion card ..... each card has 4 relays  
**CARD-BMS16** voltage current converter Card..... each board connects up to 16 probes

### GENERAL INFORMATION

Operating temperature ..... -10°C + 60°C  
Maximum distance between sensors and control unit .....100 m  
Max. distance between battery and unit..... 0,5 m  
Cable diameter for connecting sensors ..... 1 mm<sup>2</sup>  
Connection: **The cable of connection of the probe must not be installed together with the power cables. OTHERWISE, MAKE SURE TO USE A SHIELDED CABLE**

### DIMENSIONS

**BX316-** Omega bar dimensions DIN EN 50092 9 modules ..... 158x90x58 mm  
Degree of Protection ..... in air IP20

**Optional cabinet for BX316xp, Degree of protection: IP65** composition:

a) Omega bar for BX316xp insertion, b) Switching Power Supply 110 ÷ 240 VAC 75/100 W 12 VDC), c) Control unit and power supply wiring, d) Battery holder bracket

**Dimensions for 1 control unit: 330x340x160**, Dimensions Packaging: 330x380x190, Weight: 3100 grams approx.

**Dimensions for 2 control unit: 340x450x160**, Dimensions Packaging: 350x390x190, Weight: 3400 grams approx.

## Precautions

**CHECK** the integrity of the probe after having removed it from the box both in the Optional cabinet version, both in the Omega bar version.

Check that the power supply to be supplied to the appliance is compatible with the limits illustrated above. When doing the electrical connections, follow the drawing closely.

Any use of the detector for purposes other than the intended one is considered improper, and as a result of which **BEINAT S.r.l.** therefore disclaims any responsibility for possible damages caused to people, animals or objects.

**IMPORTANT:** the functioning test should not be carried out with the gas tap as this is not the case guarantees sufficient concentration to activate the main alarm.

**TERMS and EXPECTATIONS:** The installation of the **BX316xp**, its ordinary and extraordinary maintenance, and its out of service removal at the end of the functional life guaranteed by the manufacturer, must be carried out by **authorized and/or specialized personnel**.

To use your control unit for a long time and with satisfaction, use it keeping in mind the following precautions **Do not allow it to become wet.**

The control unit is not waterproof if immersed in water or exposed to high humidity, it can be seriously damaged.

**Do not drop it.**

Heavy knocks or falls during transportation or installation can damage the appliance.

**Avoid abrupt temperature fluctuations.**

Sudden temperature variations can cause condensation and the probe could work poorly.

**Cleaning**

Never clean the device with chemical products. If necessary, wash with a moist cloth.

## Compatible Probes

Probe	SENSOR	DEGREE Protec.	<u>Suitable for</u> Zone	GAS Detected	RANGE Working	OUTPUT	Accuracy	Calibration Automatic	RELAY
SG500	Catalytic	IP30	Household	CH4-LPG	0÷100% LEL	4÷20 mA	±5 %	N O	N O
SG544	Catalytic	IP44	Tertiary	CH4-LPG	0÷100% LEL	4÷20 mA	±5 %	N O	N O
SGM595	Catalytic	IP55	Tertiary	See catalyst	0÷100% LEL	4÷20 mA	±5 %	S I	N O
SGM595/A	Catalytic	IP66	Zone 2	See catalyst	0÷100% LEL	4÷20 mA	±5 %	S I	N O
SGM533	Catalytic	IP55	Tertiary	See catalyst	0÷100% LEL	4÷20 mA	±5 %	S I	S I
SG800	Catalytic	IP66	Zone 2	See catalyst	0÷100% LEL	4÷20 mA	±5 %	S I	S I
SG850 O <sub>2</sub>	Fluor. optical	IP64	Zone 2	Oxygen	In %	4÷20 mA	±5 %	S I	S I
SG850 CO <sub>2</sub>	Infrared rays	IP66	Zone 2	carbon dioxide	0÷100% LEL	4÷20 mA	±5 %	S I	S I
HCF100	SemiConduct	IP55	Tertiary	FREON	0÷300% ppm	4÷20 mA	±5 %	N O	S I
SG895	Catalytic	ATEX	Zone 1	See catalyst	0÷100% LEL	4÷20 mA	±5 %	S I	N O
SG580	Catalytic	IP66	Zone 2	See catalyst	0÷100% LEL	4÷20 mA	±5 %	N O	N O
SGF100	Catalytic	IP64	Zone 2	METHANE	0÷100% LEL	4÷20 mA	±5 %	S I	S I
SGF102	Catalytic	IP64	Zone 2	LPG	0÷100% LEL	4÷20 mA	±5 %	S I	S I
SGF104	Optical fluoresce	IP64	Zone 2	Oxygen	In %	4÷20 mA	±5 %	S I	S I
SGF106	SemiConduct	IP64	Zone 2	FREON	0÷300% ppm	4÷20 mA	±5 %	S I	S I
SGF108	Electrochemical	IP64	Zone 2	H2S	0÷300% ppm	4÷20 mA	±5 %	S I	S I
SGF110	Electrochemical	IP64	Zone 2	CO	0÷300% ppm	4÷20 mA	±5 %	S I	S I
SGF112	Catalytic	IP64	Zone 2	Hydrogen	0÷100% LEL	4÷20 mA	±5 %	S I	S I
CO100r	Electrochemical	IP55	Terziario	CO	0÷300% ppm	4÷20 mA	±5 %	S I	S I
CO100Ar	Electrochemical	IP66	Zone 2	CO	0÷300% ppm	4÷20 mA	±5 %	S I	S I
SG800 <sup>duct</sup>	Catalytic	IP66	Zone 2	CH4-LPG	0÷100% LEL	4÷20 mA	±5 %	S I	S I
CO200 <sup>duct</sup>	Electrochemical	IP66	Zone 2	CO	0÷300% ppm	4÷20 mA	±5 %	S I	S I

**Application in:**  
**Domestic:** family accommodation. Local boilers up to 70 kW-h  
**Tertiary Areas:** Large Rooms Boilers, Workshops, Material Deposits, Industrial Kitchens, Large Buildings, Buildings.  
**Zone 2 - Mixed IP66 ATEX:** High probability of escape, high risk locations, premises for which applicable regulations apply.  
**Zone 1 - Hazardous Area, High Risk Hazards, Rooms for Which Regulations, Tanks, Control Valves are in force.**

**The installation of the gas detection system does not exonerate.** From the observance of all the rules regarding the characteristics, the installation and the use of the gas appliances. The ventilation of the premises and the discharge of the combustion products prescribed by the **UNI standards as per ART. 3 LAW 1083/71** and the relevant provisions of law.

# Control unit from 1 to 16 conventional sensors BX316 Rev. 4

## Instruction manual

### {a} OVERVIEW

- Power supply 110/240 VAC
- Controls up to 16 remote sensors,
- Manages explosive and toxic gases.
- Manages up to 16 remote expansion cards: relay card and current / voltage conversion card
- Manual alarm managed by remote button
- Various possibilities of parameter configuration
- Status indications with LED
- Output signals in alarm supplied via 4 relays.
- Fault output signals supplied via 1 relay
- Output signals in fault supplied via 1 relay
- Output signals for the external siren supplied via 1 relay
- wall support 9 DIN modules.
- Conforms to the operating regulations EN60079-29-1

### {b} GENERAL DESCRIPTION

The BX316xp is a control unit capable to control the concentration of gas up to 16 input channels, each of which can be connected via a 4-20 mA communication to a toxic or explosive gas detection/measurement device. The control unit is built with the following I/O interfaces.

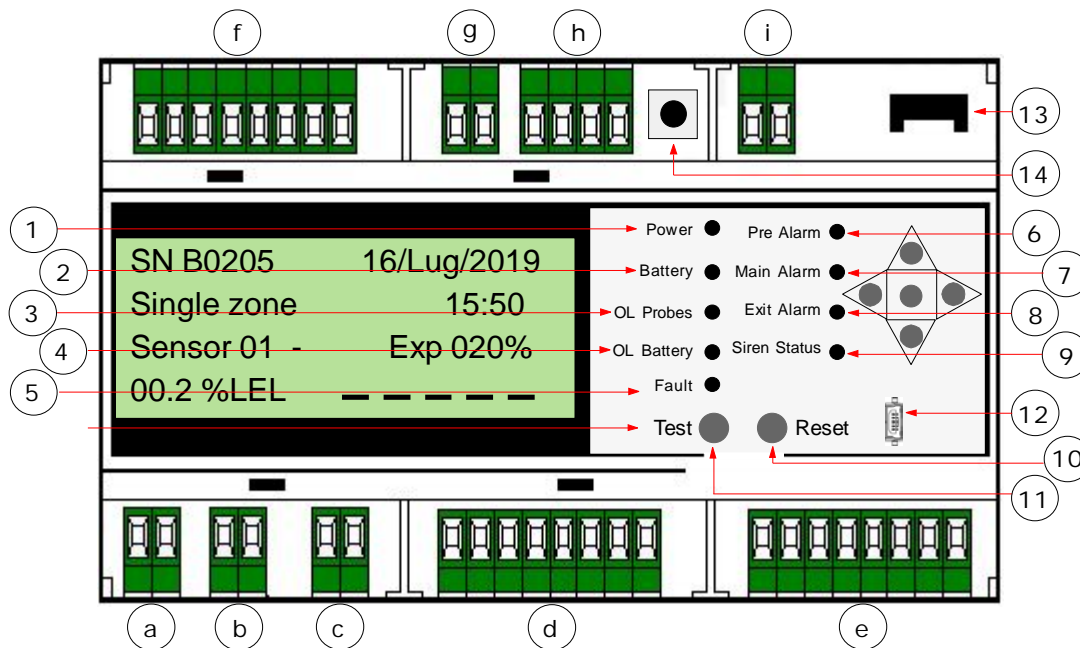

#### ignaling LEDS Power on

1) **MAINS** LED. It turns on when network voltage is inserted.

2) **Battery** LED.

This LED lights up when the control unit is powered by the battery (in the absence of mains) and flashes when the battery voltage is less than 10.8 V..

3) **PROBE OVER LOAD** LED: if this LED turns on, it indicates a short circuit or a high absorption of current by the probes and the relative connection cables. Check the battery and the connection cables.

4) **BATTERY OVER LOAD** LED: if this LED turns on it shows that the battery is connected incorrectly or there is an abnormal current absorption. Check the battery and the connection cables.

5) **FAULT** LED. This LED lights up and flashes when one of the connected probes is faulty, the connection cables are interrupted, or there is a connection error. When this LED is on, the device is no longer able to detect and activates all the relays, both on the 1st threshold and on the 2nd threshold.

To restore the operation, the probe must be repaired or removed using the setting program and the RESET button must be pressed.

This signal is type "autoreset"

- 6) **PRE-ALARM LED**(PRE-ALARM). This LED lights up when the gas concentration level has reached the pre-alarm threshold, which can be modified by the user (see dedicated chapter).
- 7) **MAIN ALARM** (GENERAL ALARM) LED. This LED lights up when the concentration level of the gas has reached the Alarm threshold, which can be modified by the user (see the dedicated chapter).
- 8) **MANUAL ALARM** LED. This LED lights up when you press the remote alarm button, at the same time the word "BTN" appears on the display
- 9) LED for activating the **EXTERNAL SIREN**. It turns **RED** when the external siren is **disconnected**. To access this function, the password must be used
- 10) **TEST button**. By keeping this button steadily pressed you will simulate a gas leak.
- 11) **RESET button**. Press this button to reset all memories.
- 12) **Printer** USB port. Connection to print the data stored in the memory.
- 13) Quick-fit socket for inserting expansion cards.
- cod. **CARD-RLS4** Relay expansion card, cod. **CARD-BMS16** conversion board from current to voltage
- 14) **Restart button**. It is used to Reset the control unit without having to remove primary voltage.

**i) External manual alarm button.**

The control unit is designed to be connected to a manual alarm button. Pressing the button the control unit will go directly into alarm even when it is in the programming state or warm up, closing all the auxiliaries connected to it.

When pressed on the Display the following message appears:

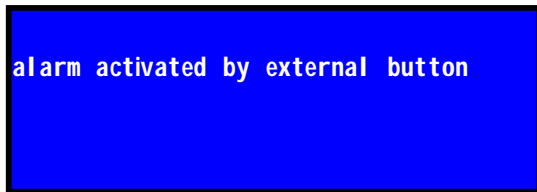

Group of navigation buttons. These buttons are used to set the operation of the control unit.

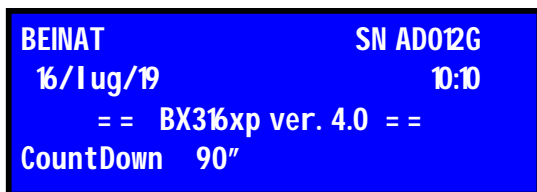

Screen that appears when the **BX316xp** is turned on. This screen remains on for 90 seconds.

- **FAULT RELAY**: this "latching" relay switches when there is an error signal from the connected sensor (see image below).
- **PRE-ALARM RELAY**: this "autoreset" relay switches when the detected gas concentration exceeds the second pre-alarm threshold.
- **MAIN ALARM RELAY**: this "memory" relay switches when the detected gas concentration exceeds the main alarm threshold.

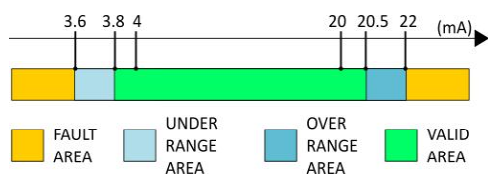

**WARNING!**

All relay outputs of the control unit are voltage free. The maximum range of such contacts is specified in the next chapters.

{c} OPERATING INSTALLATION INSTRUCTIONS



**WARNING!**

The installation parameters modification must be performed by qualified personnel. Be sure to disconnect the controller from the power supply before making changes to the connections.

**ELECTRICAL CONNECTION**

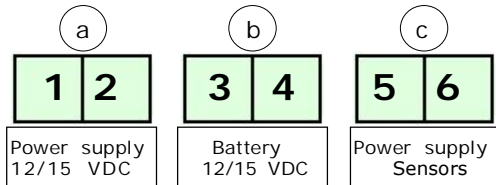

- Terminals 1 and 2: Main power supply
- Terminals 3 and 4: Secondary Power, Battery
- Terminals 5 and 6: Power supply Detection probes

- a) Connect the terminal to the primary power supply; 1 to **Positive**, terminal 2 to **Negative**
- b) Connect the terminal to the secondary power supply (optional back-up battery); 3 to **Positive**, terminal 4 to **Negative**

- c) To Power on the detection sensors Connect; 5 to **Positive**, terminal 6 to **Negative**

**Note.** Power the system only when all the parameters have been configured.

Then connect the sensors and the battery (optional) to the signal terminal block

**SENSORS RETURN SIGNAL CONNECTION**

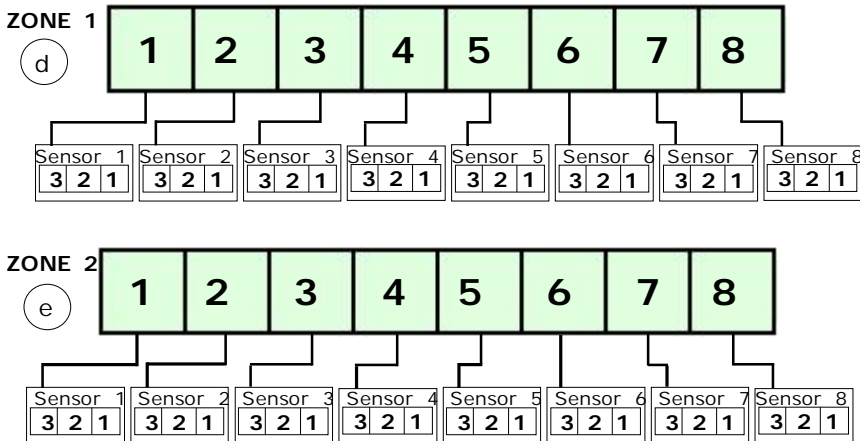

The signal terminal blocks for the GAS detection (previous figures) are composed as follows:

- **Terminals of the terminal board (d) Zone 1**  
1, 2, 3, 4, 5, 6, 7, and 8: Connection return signal of 4-20 mA GAS sensors.
- **Terminals of the terminal board (e) Zone 2**  
1, 2, 3, 4, 5, 6, 7, and 8: Connection return signal of 4-20 mA GAS sensors.

**WARNING!**

- The optional battery is charged directly from the control unit.
- This control unit can connect up to 16 probes divided into two zones.
- Each probe must conform to the 4-20 mA current loop system on this terminal block.
- Connect the probes as shown in the figure

## RELAY CONNECTIONS

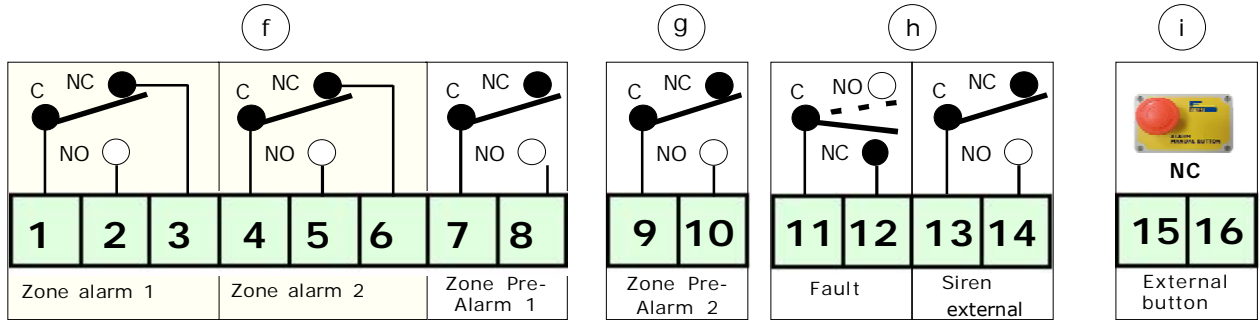

a) Connect the desired utilities to the output relays described above according to your needs.

- **FAULT RELAY:** this "latching" relay switches when there is an error signal from the connected sensor
- **PRE-ALARM RELAY:** this "autoreset" relay switches when the detected gas concentration exceeds the second pre-alarm threshold.
- **MAIN ALARM RELAY:** this "memory" relay switches when the detected gas concentration exceeds the main alarm threshold.

b) To connect the external alarm button, follow the instructions on page 5

## EXPANSION CARDS

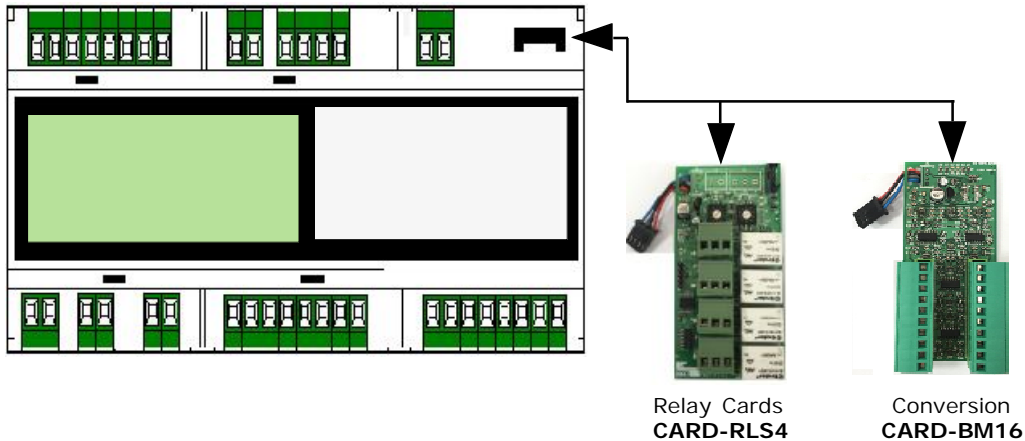

- Up to a maximum of 16 Mixed Expansion Cards can be connected between:
    - Relay Card **CARD-RLS4**, having 4 relays each. the relays can be associated with the desired probe
    - CARD-BSM16** card, Voltage Current conversion for all 16 probes
- Each relay can be associated with the following functions: Pre-Alarm, Alarm, Fault or not used

## DIMENSIONS

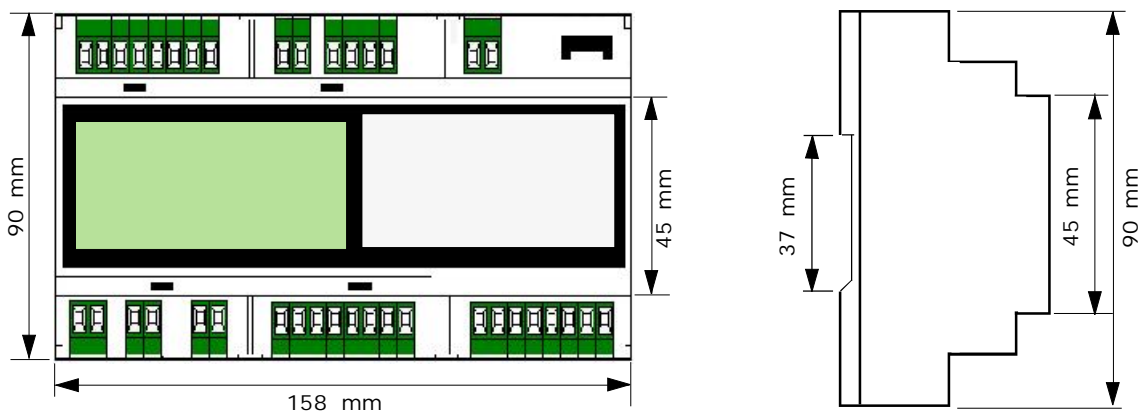

Initial Screen

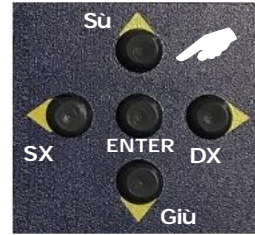

In normal functioning state, the display shows the following information:

- Registration number
- Current date and time
- Currently detected zone; the control unit can be divided in zones: Single Zone - Zone 1 - Zone 2
- The currently monitored probe, and the type of gas, explosive and/or toxic.  
Each connected probe is shown every 8 seconds.  
To ACCELERATE THE DISPLAY OF THE PROBES PRESS THE **DX** AND **SX** BUTTONS.  
To stop the sequence of probes, and analyse the functioning of a specific probe, press **"ENTER"**.  
On the display you will see a key. To unlock it, press again **"ENTER"**.
- Display of the percentage of L.E.L. or ppm detected by the probe, and the bar graph of the quantity of gas.

Settings

To access the **BX316xp** setting program you should press the **"ENTER"** button for 5 seconds.



To continue you should enter a password.

The **"password"** is **1-2-3-4**.

The password can be changed by accessing the **"Advanced Functions"** in the **"General Functions"** section.

Use the **Left** and **Right** buttons to reach the desired number, and press **"ENTER"**.

Each time you enter a number you will see an a star, until all four a stars appear.

If the password is correct you will see **"Password accepted"**

If you made a code input mistake, you will see **"Wrong password"**.

You should re-enter the password. If you do not press any key, you will return to the previous screen.

Setting and Functions

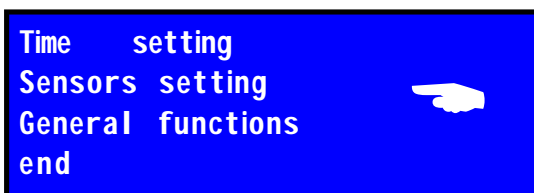

#### DATE and TIME SETTING

Use the **SU** and **GIÙ** buttons to select **"Time Setting"**, and press **"ENTER"**. You will access the current date and time setting program to set **date and time**

#### SENSOR SETTING

Use the **SU** and **GIÙ** buttons to select **"Sensor Setting"**, and press **"ENTER"** to access the program

- Selection of the division into zones: **1 zone or 2 zones**
- Set the **quantity of probes**, and the **type of gas for which the probe is set**.
- Set the **percentage of gas** of the Pre-Alarm, and the **Operating Range**, of each probe.

#### GENERAL FUNCTIONS

Use the **SU** and **GIÙ** buttons to select **"General Functions"**, and press **"ENTER"** to access the program to select: relay functioning mode, intrinsic safety function activation, activation of the zone alarm latching function, activation of the external siren in silent mode, and **"Advanced Functions"** menu.

Selecting the **"Advanced Functions"** you access to:

**PASSWORD CHANGE, DATA LOGGER READING, EVENT PRINTING, PROBE TEST, MAINTENANCE, EXPANSION CARDS, FACTORY RESET**

Select **END** to return to the initial screen



Date and Time setting...Follows

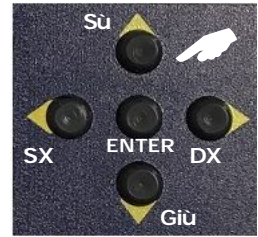

To set the date and time, proceed as follows:

- 1) Use the **DX and SX** buttons to select **DAY, MONTH, YEAR, HOUR, MINUTES.**
- 2) Use the **ENTER** button to find the desired day, month, year, hour, minutes.

**Note.** In case of blackout the **BX316xp**, the set data are not lost.

If the backup clock battery is too low, you will get this error message **"Err. bat. Clock"** during the warmup phase.

**End:** to exit the program, select **" Return Arrow "**.. ◀

### PROBE SETUP

Probe setting, selection of the zones to be controlled

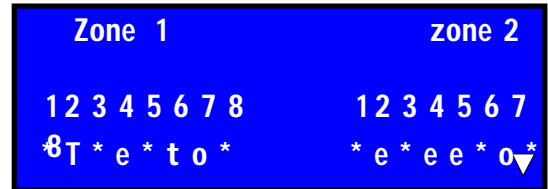

#### selecting zone to control

As explained above, you can divide the control unit in multiple zones in order to set one or more alarm handling modes.

Initially, this screen will display the **"Single Zone"** blinking message.

Press **"ENTER"** to replace the previous message with **"Zone 1 – Zone 2"**.

In **Single Zone** mode, you will control a **single relay** for the **Main Alarm of all 16 probes.**

In **Zone 1-2 mode**, you will control **two relays** for the Main Alarm:

**1ST RELAY FOR PROBES 1 TO 8 AND 2ND RELAY FOR PROBES 9 TO 16**

Probe setting, probe acquisition and gas type

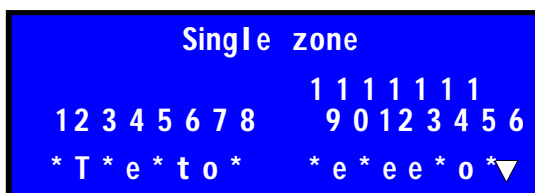

#### Enabling or disabling probes and Gas Type Selection

By pressing **GIU'**, the probe 1 asterisk starts to flash, each time **"ENTER"** is pressed, the asterisk changes to: **"E"** THIS MEANS PROBE 1 ENABLED FOR EXPLOSIVE GAS.

**LEGEND**  
 \* DISABLED SENSOR  
 E, YOU HAVE ENABLED A PROBE FOR EXPLOSIVE GAS  
 T, YOU HAVE ENABLED A PROBE FOR TOXIC GAS  
 O, YOU HAVE ENABLED A PROBE FOR OXYGEN GAS

Use the **DX** and **SX** buttons to select the desired probe, and repeat the operation outlined above. This operation should be performed on all probes to be activated.

Probes setting, storage selection

Use the arrow down to the right and press **"ENTER"** to access the setting program for the pre-alarm gas percentage.

Probe setting, alarm storage for each probe

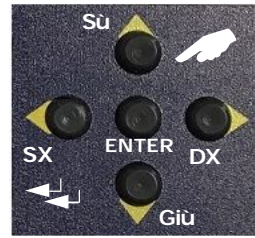

Alarm Memory

Depending on the type of system, you can choose to insert or deactivate the **memory**. Choosing the **memory** function, the control unit will keep the relay closed until the Reset button is pressed.

Depending on the type of system, you can choose to insert or deactivate the Storage. Choosing the Storage function, the control unit will keep the relay closed until the Reset button is pressed.

**IN COMPLIANCE WITH THE EN 60079-29-1 STANDARD, MEMORY RETENTION CANNOT BE DEACTIVATED FOR THE DETECTION OF EXPLOSIVE GASES READING IN "LEL".**

The control unit will not keep the relay closed when the gas saturation level ceases, it automatically resets.

Single zone

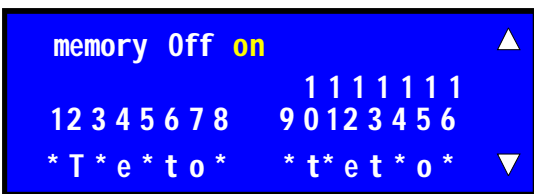

Zone 1

Zone 2

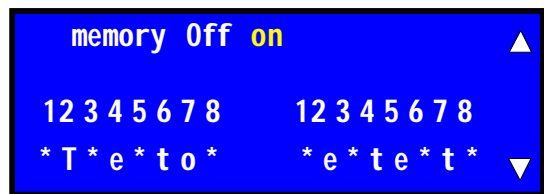

**MEMORISATION CHOICE**

With the "DX" and "SX" buttons, position yourself in the desired probe.

**Warning!** Only for probes intended for detection of toxic gas. Each time the "ENTER" button is pressed, the ON/OFF message will change.

- ▲ Indicator to return to the previous page, select with the "SU" and "GIU" buttons and press "ENTER"
- ▼ Indicator to go to the pre-alarm threshold selection page, select with the "SU" and "GIU" buttons and press "ENTER"

Probe setting, selection of the thresholds: Pre-alarm and alarm

**Configuration of the pre-alarm threshold**

The program of the control unit foresees that each connected probe can have a pre-alarm threshold different from another.

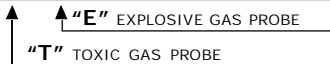
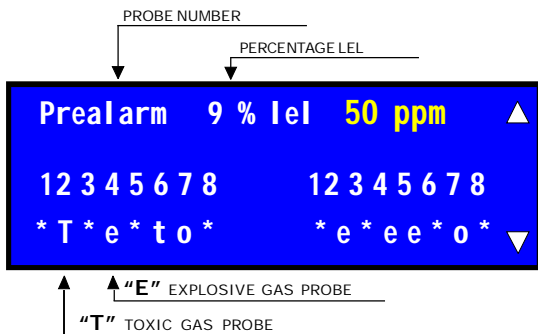

Press the "DX" and "SX" buttons and move to the desired probe, (in the drawing the 4). To change the value press the "ENTER" key as many times as necessary to establish the desired data. For each probe the pre-alarm can be selected from: **5% and 9% of the LEL**, in 1% steps, for explosive gases **75 and 135 ppm** in 15 ppm steps, for toxic gases. When you exit the page, the data remains stored.

- ▲ Indicator to return to the previous page, select with the "SU" and "GIU" buttons and press "ENTER"
- ▼ Indicator to go to the **ALARM THRESHOLD** selection page, select with the "SU" and "GIU" keys and press "ENTER"

**ALARM THRESHOLD SETTINGS FOR EACH PROBE**

**Configuration of the general alarm threshold**

The program of the control unit foresees that each connected probe can have an alarm threshold different from another.

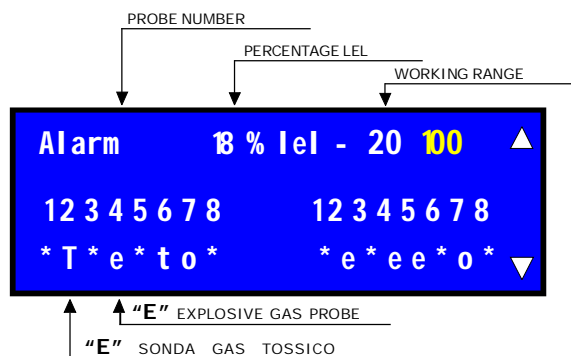

**THE ALARM THRESHOLDS FOR EXPLOSIVE GAS ARE DIVIDED AS FOLLOWS:**

- 1ST SCALE FROM 10 TO 20% OF LEL WITH 1% STEPS
- 2ND SCALE FROM 10 TO 50% OF LEL IN 5% STEPS

For obvious reasons, the two scales are subordinated by: Working range selected in the probes.  
 range of work selected in the 20% probes = 10-20% scale  
 range of work selected in the 100% probes = 10-50% scale

**SCALE 10-20%**

THE FIRST SCALE OF 10-20% OF THE LEL CAN BE CONFIGURED AS DESIRED, TAKING INTO ACCOUNT THAT THE INTERVENTION THRESHOLD CANNOT BE LESS THAN THE PRE-ALARM.

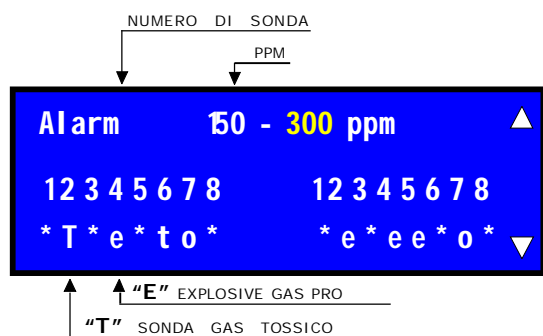

**THE TOXIC GAS ALARM THRESHOLDS ARE DIVIDED AS FOLLOWS:**

- 1ST SCALE FROM 150 TO 300 PPM WITH 15 PPM STEPS

▲ Indicator to return to the previous page, select with the "SU" and "GIU" buttons and press "ENTER"

▼ Indicator to go to the selection page: "Operating range selection" select with the "UP" and "DOWN" keys and press "ENTER"

**SELECTION OF OPERATING RANGE**



The control unit foresees that each connected probe can have a different **operating range** from one another except for the detection of oxygen.

**Note.** OPERATION RESERVED EXCLUSIVELY FOR EXPLOSIVE GAS.

THE OPERATING RANGE IS FACTORY SET AT 20%

Proceed by selecting the desired probe, press "ENTER" the Display changes state and appears as shown in the figure below.

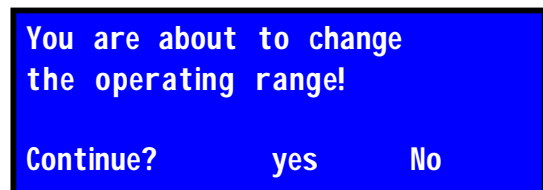

Given the importance of this operation, confirmation is required to be able to proceed with the modification of:

**Operating Range.**

Select "yes" or "no"

Press yes to continue

the operating range changes from 20 to 100%



Operating range changed from 20 to 100% of the LEL

warning!

When the operating range is changed on the control unit **Remember to change it also on the probe concerned.**

▲ Indicator to return to the previous page, select with the "SU" and "GIU" buttons and press "ENTER"  
**ALARM THRESHOLDS FOR EXPLOSIVE GAS**

◀ Indicator to exit the program, select with the SU" and "GIU" keys and press "ENTER"

**ALARM THRESHOLD SETTINGS FOR EACH PROBE OVER 20%**

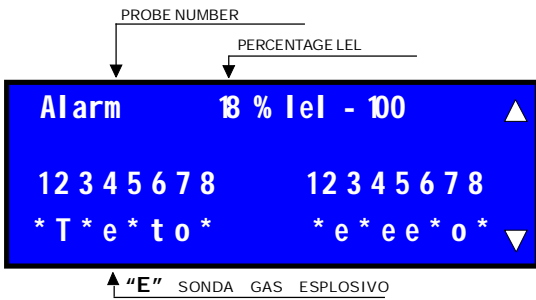

**AFTER SETTING THE OPERATING RANGE**

**SCALE VARIATION: SCALE 10-50%**

USE THE "DX" AND "SX" BUTTONS TO POSITION YOURSELF IN THE DESIRED PROBE.

TO CHANGE THE VALUE PRESS THE "ENTER" KEY.

GIVEN THE GREAT IMPORTANCE OF THIS OPERATION, THE PASSWORD IS REQUIRED BEFORE PROCEEDING WITH THE CHANGE.

**ENTERING THE PASSWORD TO CHANGE THE ALARM THRESHOLD**  
before doing this, remember to: configure the **probe and the control unit**

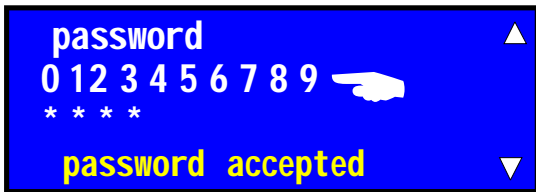

The "password" is that of the "PUK".

Scroll with the **DX** and **SX** keys over the required number, press "ENTER", each number entered turns on an asterisk, continue entering the password until the four asterisks are lit ...

**password accepted.**

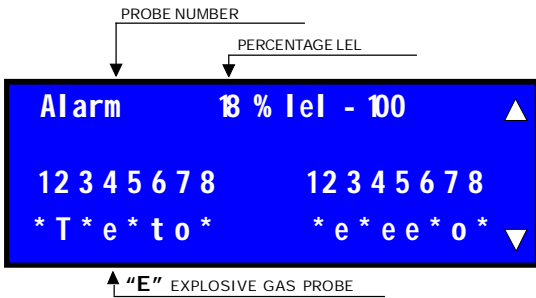

**AFTER ENTERING THE CORRECT PASSWORD**

**SCALE VARIATION: SCALE 10-50%**

WITH THE "DX" AND "SX" BUTTONS, POSITION YOURSELF IN THE DESIRED PROBE.

TO CHANGE THE VALUE, PRESS THE "ENTER" KEY

▲ To exit the program: go to the next page, selecting it with the "UP" and "DOWN" buttons and press "ENTER" (operating range)

◀ Indicator to exit the program, select with the **SU** and **GIU** keys and press "ENTER"

**DETECTION SETTINGS**  
OXYGEN GAS

To set the probes for OXYGEN, move DX and SX buttons to probe 1 (our case). The letter "O" (oxygen) is displayed. All probes for OXYGEN have a fixed setting both of Pre-alarm than alarm. See table of thresholds on the side.

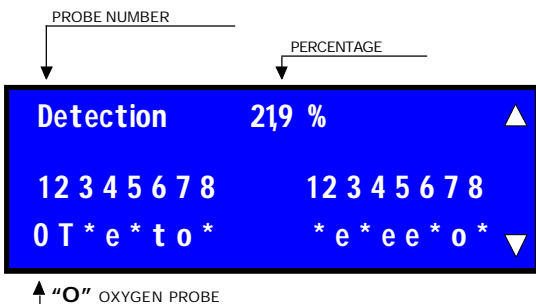

<b>Pre-Alarm</b>	<	19.9 %	<b>Legend:</b> < OXYGEN DEFICIENCY > EXCESS OXYGEN
	>	21.9 %	
<b>Alarm</b>	<	18.5 %	
	>	23.5 %	

▲ Indicator to return to the previous page, select with the **"SU"** and **"GIU"** buttons and press "ENTER"

▼ Indicator to go to the operating range threshold selection page, select with the **"SU"** and **"GIU"** keys and press "ENTER"

## Programs and General Functions

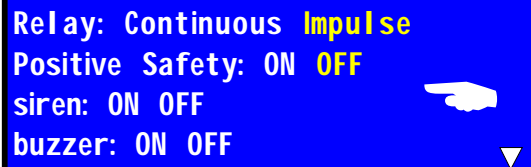

Relay: Continuous **Impulse**  
Positive Safety: ON **OFF**  
siren: ON OFF  
buzzer: ON OFF



### SELECTION OF THE GENERAL ALARM RELAY WORKING MODE

Depending on the type of system, it is possible to select the relay work mode in two distinct modes: **continuous and impulse**.

In "**Continuous**" mode the relay remains closed for the entire duration of the alarm condition (if "**memory**" is selected, the relay will remain switched until the RESET button is pressed).

In "**Impulse**" mode the relay remains closed for 20 seconds, after which it is de-energized.

Each time the "**ENTER**" button is pressed, the message **Continuous-impulse** will change. Once chosen, move with the **SU**" and "**GIU**" buttons on the next selection.

### selection of positive safety

Depending on the type of system, there may be a need to select **Positive Safety**.

In this mode the operation of the two manual alarm relays is reversed.

Selection

Use the **SU**" and "**GIU**" keys to select the Sic message. **Positive Safety**.

Each time the "**ENTER**" button is pressed, the **ON / OFF** message will change.

In the "**ON**" position, the Positive Safety function is activated.

In the "**OFF**" position, the Positive Safety function is deactivated.

Once chosen, move with the **SU**" and "**GIU**" buttons on the next selection.

### Silencing of Siren and Buzzer

The program of the control unit foresees the possibility of silencing both the external siren and the Buzzer, which could be dangerous during the testing phase, or during prolonged alarms.

The silencing of the external siren is signaled by an LED on the front panel.

**Red LED** illuminated: silenced siren; Led off: siren in operation.

Siren selection

Select the word Siren with the **SU**" and "**GIU**" keys

Each time the "**ENTER**" button is pressed, the **ON / OFF** message will change.

In the "**OFF**" position the Siren is silenced; The LED on the panel lights up.

In the "**ON**" position the Siren is enabled; The LED on the panel goes out.

Buzzer selection

Select the **SU**" and "**GIU**" buttons Buzzer

Each time the "**ENTER**" button is pressed, the **ON / OFF** message will change.

In the "**OFF**" position the Buzzer is silenced.

In the "**ON**" position the Buzzer is enabled.

▼ Indicatore per passare alla pagina di **FUNZIONI AVANZATE**, selezionare con i tasti "**SU**" e "**GIU**" e premere "**ENTER**"

### Advanced Functions



Advanced Functions

Select Advanced Features and press "**ENTER**" to go to the next program

▲ Indicatore to return to the previous page, select with the "**SU**" and "**GIU**" buttons and press "**ENTER**"

▼ Indicatore to go to the operating range threshold selection page, select with the "**SU**" and "**GIU**" keys and press "**ENTER**"



Change Password

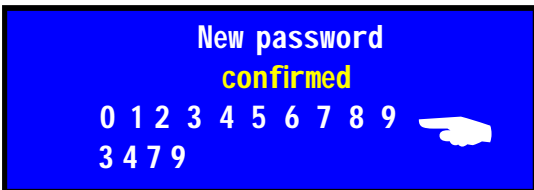

Move with the **DX and SX** buttons over the desired number and press "ENTER", each time the number selected will light up. Proceed with the insertion until all four numbers are turned on.

Once entered, the word "**CONFIRMED**" lights up.

Memorize your password and don't forget it !!

From this moment, to access the ECU programming, the new **Password** must be entered.

If you forget your password you can find the "**PUK**" number written on the warranty sheet.

After the change the program switches to the next function. "Data logger"

Reading the data logger

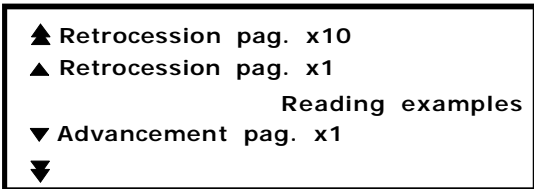

Scroll the pages with the **SU**" and "**GIU** buttons by selecting **x1 or x10** depending on the type of advancement / withdrawal required, and press "ENTER"

**This chapter requires special attention** because all the anomalies that occurred during the operation of the entire system are recorded.

In fact, all security and general fault events are stored in the data logger, including network blackouts, battery operation or discharge, etc.

See the table below.

All data is stored with codes, each code corresponds to an event.

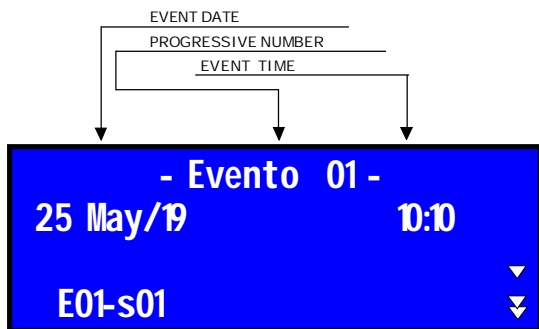

Type of event	Code
1 Pre-alarm	E00-S01
2 Alarm	E01-S01
3 Generic Fault Probe	E02-S01
4 Black out	E03-C00
5 Voltage recovery	E04-C00
6 Low battery	E05-C00
10 Probe off	E09-S01
11 Device reset	E10-C00
12 Clock battery	E11-C00

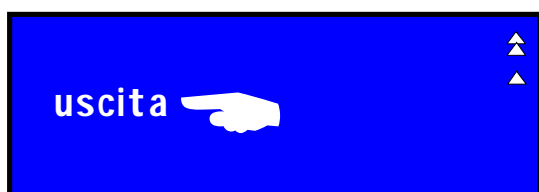

Programs and General Functions, advanced functions

PRINT CURRENT STATUS AND EVENT LOG

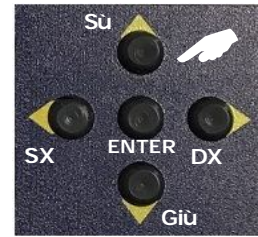

Select the desired one with the UP and DOWN keys:

- a) **Print status**, press "**ENTER**".  
Print the current status of the control unit and the probes.
- b) Print the data from the Datalogger, press "**enter**".  
Print all stored events.

STATE RECEIPT

DATA LOGGER RECEIPT

```

BEINAT
== BX316xp ==
Ver: 4.0 S/N Sample
Serial number: 0102
Date      Hour
07/MAG/19 10:00

State probes
-----
Probe 01      Zone 1
Gas Type: Explosive
Gas Level:    02.9 LEL
Meas.Current: 06.2 mA
Status: Normale
-----
Probe 02      Zone 1
Disabled
-----
Probe 03      Zone 1
Disabled
-----
    
```

```

BEINAT
== BX316xp ==
Ver: 4.0 S/N Sample
Serial number: 0102
Date      Hour
07/MAG/19 10:00

Datalogger
-----
- Event 01 -
06/jun/2010 08:27
Reset
-----
- Event 02 -
07/jun/2010 10:11
Hard Reset
-----
- Event 03 -
07/jun/2010 10:27
Vbat=11.8V
-----
    
```

- ▲ Indicator to return to the previous page, select with the "**SU**" e "**GIU**" buttons and press "**ENTER**"
- ▼ Indicator to go to the alarm threshold selection page, select with the "**SU**" and "**GIU**" keys and press "**ENTER**"
- ◀ Indicator to exit the program, select with the keys "**SU**" and "**GIU**" press "**ENTER**"

DETECTION PROBES OPERATION CHECK

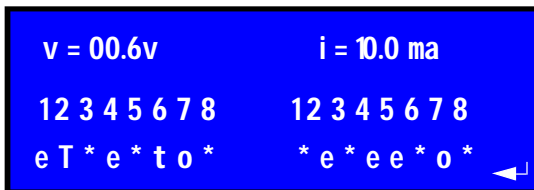

**This chapter** is very useful for the functional control of the gas detection probes.

**We remind** you that all conventional probes transmit the signal to the control unit in **current from 4 to 20 mA values**

- 4 mA resting phase no gas
- 20 mA gas presence alarm phase

**Conventional Probe Test**

In the start-up phase The cursor positions itself on **probe 1**, at the same time **it reads both the voltage and the current detected by the probe.**

To read the other probes, move with the **DX** and **SX** buttons over the desired probe.

- ◀ Indicator to exit the program, select with the "**UP**" and "**DOWN**" keys and press "**ENTER**"

## Programs and General Functions, advanced functions

### MAINTENANCE PROGRAM

The Beinat always attentive to the needs of its customers, has introduced in this control unit a new **innovative feature** .....

This mode is used to ensure that the gas flow is not interrupted during maintenance operations. This mode also inhibits the external siren.



The interruption period is managed directly by the technician based on the size of the installation. Position yourself above the word: "maintenance: 00" after ... Each time the "ENTER" button is pressed, the time changes to: **15 - 30 - 45 - 60 minutes maximum.**

N.B. At the end of the countdown the device returns to normal operating status.

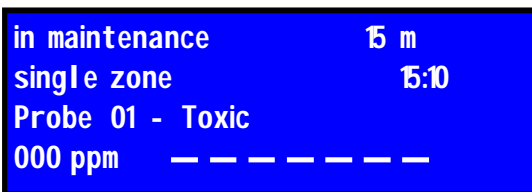

During the maintenance period, the wording "in Maintenance" and the remaining minutes are displayed. (15m = countdown time)

#### Maintenance interruption

If the job ends before the set time, pressing the "RESET" button exits the maintenance cycle.

▲ Indicator to return to the previous page, select with the ""SU" and "GIU" buttons and press "ENTER"

◀ Indicator to go to the operating range threshold selection page, select with the "SU" and "GIU" keys and press "ENTER"



#### Functional test with GAS Pre-Calibrated and control tester

The user periodically at least every 6 months, must carry out a verification of the functioning of the system by spraying a special test gas at the base of the connected probes until obtaining the alarm status.

#### At least once a year

A more accurate check must be carried out by a specialized technician who must issue the verification certificate with the **Beinat TS1008 tester.**

The decommissioning of the system must be carried out by a specialized technician.

### FACTORY RESET

#### Factory Reset

The program requires that the control unit can be reset to the initial factory data if necessary.

**Warning!** using this program, all user-entered data is deleted.



Select "Factory reset", Pressing "ENTER" the writing starts to flash.

Holding down "ENTER" after 4 seconds a grid appears with 10 empty rectangles that gradually fill up, at the end of which the **BX316** is totally reset, and starts a new countdown that lasts 90 seconds.

▲ Indicator to return to the previous page, select with the ""SU" and "GIU" buttons and press "ENTER"

◀ Indicator to go to the operating range threshold selection page, select with the "SU" and "GIU" keys and press "ENTER"





RELAY EXPANSION CARDS

**CARD-RLS4:**

```
CARD-RLS4: 01 (Address card) 03.04 .. 16
Relay: 01 02 03 04
Function: NOT USED FAuIt ALARM PRE-ALARM
Probes: 01 - 2 3 4 5 6 7 8 9 10 11 12 13 14 15 16 ←
```

Up to a maximum of **16 CARD-RLS4 Relay Expansion cards** can be connected to the control unit. On each board there are 4 auxiliary relays, to be associated with the desired probe. With a maximum of 64 relays.

The functions related to: **Pre-Alarm, Alarm, Fault or not used** can be associated to each selected relay

Each selected relay can be associated with a specific range of probes from **1 to 16**.

#### viewing

**CARD-RLS4**- Indicates the address set in the card in reading. Each time the **ENTER** button is pressed, the **CARD-RLS4** card to be set is selected.

**Relay** - Each press of "**ENTER**" chooses the Relay (from **1 to 4**) to which you want to associate a function.  
**Func.** With each press of "**ENTER**" I choose the function to associate: not used-pre-alarm-alarm-failure PROBE. Each press of "**ENTER**" chooses the interval of the probes to which I must associate the function of the relay

Once set **to memorize**, just choose back with the return arrow.

After making all the connections and configurations, the system can be powered



#### **WARNING!**

- > This control unit is **NOT** built for installation in ATEX classified areas
- > To meet the requirements as a control unit according to the standard EN 60079-29-1: 2016 BEINAT S.r.l. has relied on programming and functions via a microprocessor with the aid of a numeric alpha display
- > All the wiring of the remote sensors must be made using wires with a minimum section of 1.5 mm<sup>2</sup> and no longer than 25 m. Do not use the same conduit for signal and power cables.
- > In case of installation in the presence of strong EMC disturbances, the shielded cables use is strongly recommended. The screen must be connected to the 'Gnd' terminal of the interested area only on the side of the control unit.
- > The appliance must be connected to the power supply by means of a switch capable of disconnecting the poles in compliance with current safety standards and with a contact separation of at least 3 mm in all poles.
- > The installation and electrical connections of this appliance must be carried out by qualified technicians and in compliance with the current technical and safety standards.
- > Be sure to turn off the power before wiring the device.
- > Safety depends on the installer (whose responsibility is to set up a detection system in compliance with existing standards, both European and national) to choose the correct type of loads to be connected to the control unit and the correct configuration of the system parameters. In case of doubt, please contact the distributor.

#### **{d} OPERATIONAL LIMITATION**

01. This device can be set for explosive, toxic gas and oxygen.
02. For transverse sensitivities refer to the remote sensor user manual.
03. Response time T90: 1 second \*
04. Temperature operating range: -10° C ÷ + 60° C
05. Humidity operating range: 0 ÷ 90% RH not condensed
06. Pressure operating range: 800 ÷ 1100 hPa
07. Power supply: 15 VDC
08. Absorption: 25W
09. Electrical wiring: see paragraph (c)
10. Batteries: max 2.2 Ah
11. Sample scope: Not applicable
12. Warm-up time: 100 seconds
13. Stabilization time: not applicable
14. Contact rating: 10A 250V
15. Variable pre-alarm range: for explosive gases set for each probe between **5% and 9% of the LEL** for toxic gases set from 75 to 135ppm
16. Variable alarm range 1: for explosive gases set for each probe between **10% and 20% of the LEL** for toxic gases alarms varying from 150 to 300 nppm
17. Variable alarm range 2: for explosive gases set for each probe between **10% and 50% of the LEL** for toxic gases alarms varying from 150 to 300 ppm
18. Protective rating: IP20
19. Weight: 260 g
20. ATEX protection: this device must be installed in NON-CLASSIFIED ATEX areas.

\* The response time of the entire system is determined by the response time of all parts of the equipment within the gas detection system.

The maximum delay time of a special status in case of transmission errors until insertion.

#### **{f} TEST**

Once activated, the control unit enters the heating phase for 90 seconds.

In this phase all the LEDs flash and the connected probes are given the time to enter full speed.

The operating status and data are read through the Display and are:

- a) Registration number
- b) Date and time in progress
- c) Intensive reading area; The control unit can be divided into zones: Single Zone, or in two zones
- d) The probe that the control unit is analyzing, and the type of gas, Explosive or Toxic, Oxygen and the operating range.

The exchange of each connected probe occurs approximately every 8 seconds, only the enabled probes are displayed.

e) Displays the percentage of the LEL or ppm that the probe is detecting and the graph of the gas quantity. At the end of this initial phase, the control unit enters detection mode.

It is therefore possible to carry out a first check of the system by pressing the test button: keeping this button pressed, the control unit simulates a concentration of gas gradually increasing by the enabled sensors, and it is therefore possible to control the switching on and off of the LEDs and that all the relays switch, enabling the users connected to them.

## {g} WORKING CONDITIONS

Depending on the input signal of the remote sensors, the control unit can be found in the following working conditions:

**NORMAL MODE:** the control unit receives a signal from the sensors corresponding to a gas level between 0% and 9% of LEL for explosive gases and between 0 ppm and 300 ppm for toxic gases.

The relays are off and no alarm or fault LED lights up. The buzzer is off.

**PRE-ALARM:** the control unit receives a signal from the sensors corresponding to an explosive gas level set for each probe between **5% and 9% of the LEL**; for toxic gases set from 75 to 135ppm.

The relays switch and the red pre-alarm LED lights up. The buzzer sounds and the display shows the% of gas detected.

**1st type ALARM:** the control unit receives a signal from the sensors corresponding to an explosive gas level set for each probe between **10% and 20% of the LEL**; for toxic gases set from 150 to 300 ppm.

The relays switch and the red general alarm LED lights up. The buzzer sounds and the display shows the% of gas detected.

**2nd ALARM type:** the control unit receives a signal from the sensors corresponding to an explosive gas level set for each probe between **10% and 50% of the LEL**; for toxic gases set from 150 to 300 ppm.

The relays switch and the red general alarm LED lights up. The buzzer sounds and the display shows the% of gas detected.

**GENERAL ALARM:** the control unit receives a signal from the sensors corresponding to a gas level higher than 20% LEL for explosive gases and greater than 300 ppm for toxic gases.

The main alarm relay also changes state and the red "20/300" LED also lights up, the "General alarm" LED flashes. The general alarm relay is energized. The buzzer is on (high frequency).

**OVER / UNDER RANGE:** the control unit receives an under / over range signal. This condition is signaled by two different flashing frequencies of the explosive gas LEDs.

The relays are off and no alarm or fault LED lights up. The buzzer is off.

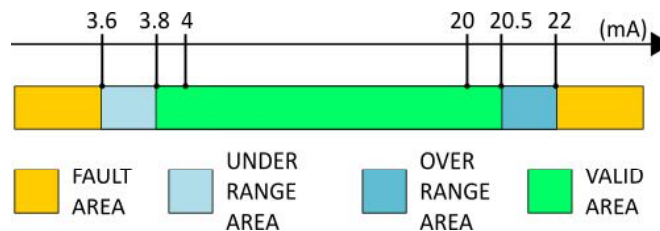

**FAULT:** the control unit receives a "short circuit" or "open circuit" signal.

The yellow fault LEDs are on. The fault relay is energized. The buzzer is on (fixed sound).

**SYSTEM ERROR:** the control unit is blocked due to an internal fatal error.

The yellow error LEDs flash. Relays are OFF. The buzzer is on (LED frequency).

## {h} TROUBLESHOOTING

### Problem.

If the Fault LED lights up, the system reports an error status.

Possible cause: The input current loop is interrupted or the probe is not powered.

### Solution:

Check the connections between the probe and the control unit for interruptions. Also check with a multimeter the presence of a voltage around 12 VDC between the "+ V" and "GND" terminals of the reference input.

## {i} PERIODIC CONTROL

**MAINTENANCE.** A periodic service must include the following operations:

**a)** (every 6 months): Check the correct operation of the detection system by applying calibrated gas to each remote sensor and checking the value.

Refer to the user manual of the sensors for more information.

**b)** (every 12 months): revision of the control unit transfer function and correct detection each zone to the significant values for example:

0 mA:	open circuit,
3,7 mA:	under range,
4-20mA:	normal operation,
21 mA:	Over range
23 mA:	fault.

The following figure shows the conversion between mA and the corresponding gas concentration.

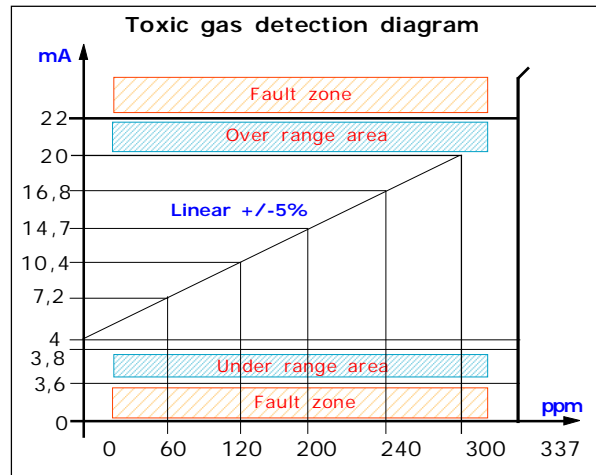
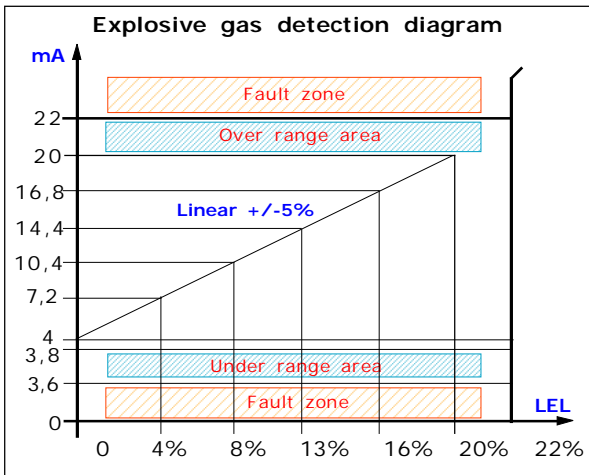

SEE Maintenance Schedule page 16



**Functional test with GAS Pre-Calibrated and control tester**

The user periodically at least every 6 months, must carry out a verification of the functioning of the system by spraying a special test gas at the base of the connected probes until obtaining the alarm status.

**At least once a year**

A more accurate check must be carried out by a specialized technician who must issue the verification certificate with the **Beinat TS1008 tester**. The decommissioning of the system must be carried out by a specialized

**{j} STOCKING**

Operating temperature range: -10 ° C ÷ + 60 ° C  
 Operating humidity range: 0 ÷ 90% RH uncondensed  
 Pressure operating range: 800 ÷ 1100 hPa

**{k} CONTAMINANTS**

Not applicable to the control unit. For the remote sensor, refer to the remote sensor user manual

**{l} AUTOMATIC RESET**

The state of the pre-alarm relay is automatically reset when the concentration falls below the pre-alarm threshold.  
 On the contrary, the status of the alarm relay CANNOT be automatically reset and remains in memory until the control unit receives a reset signal from the user. Refer to the relevant section for details.

**{m} BATTERY MAINTENANCE**

This control unit is equipped with input terminals (1 and 2) for backup of the external 12 VDC power supply. The control unit itself charges the battery up to 2.2 Ah. Battery maintenance operations must be based on what the manufacturer suggests.

## {n} SPARE PARTS

This control unit has no user serviceable parts.

## {o} ACCESSORIES

This control unit has the following accessories available:

Relay expansion card, CARD-RLS4 code

Current voltage conversion expansion board, code CARD-BMS16

## {p} WARRANTY

With a view to the constant development of its products, the manufacturer reserves the right to modify technical data and functions without prior notice.

The consumer is guaranteed for any lack of conformity pursuant to European Directive 1999/44 / EC, as well as to the manufacturer's document regarding the warranty policy.

The full text of the warranty is available upon request from the seller.

## {q} MARKED

### Example of a label



### WARNING! Actions to be taken in case of alarm

- 1) Put out all free flames.
- 2) Close the main gas tap or the LPG cylinder tap.
- 3) Do not turn any lights on or off; do not turn on any electrical device or appliance.
- 4) Open windows and doors in order to increase ventilation.

If the alarm stops, its cause must be found and the relevant consequent measures taken.

If the alarm continues and the cause of gas presence cannot be found or removed, abandon the building and call the emergency services when outside (fire department, distributors, etc.)

**IMPORTANT:** The operation test should not be carried out with the gas tap as this does not guarantee a sufficient concentration to activate the general alarm.

#### Warning !!

If you have the following symptoms: vomiting, sleepiness, or else, go to the closest first aid station and inform the operators that you could have been poisoned by **Carbon Monoxide, or by an excess or deficiency of oxygen**



{r} INSTALLATION EXAMPLES

**WARNING.**



Before connecting to the mains power, ensure the voltage is correct. Carefully follow the instructions and the connections according to Regulations in force, keeping in mind that the signal cables should be laid separate from the power cables. An automatic cut-off switch (appropriately identified as devicesectioning of the detector) should be incorporated in the electrical system, adequately located and easily accessible.

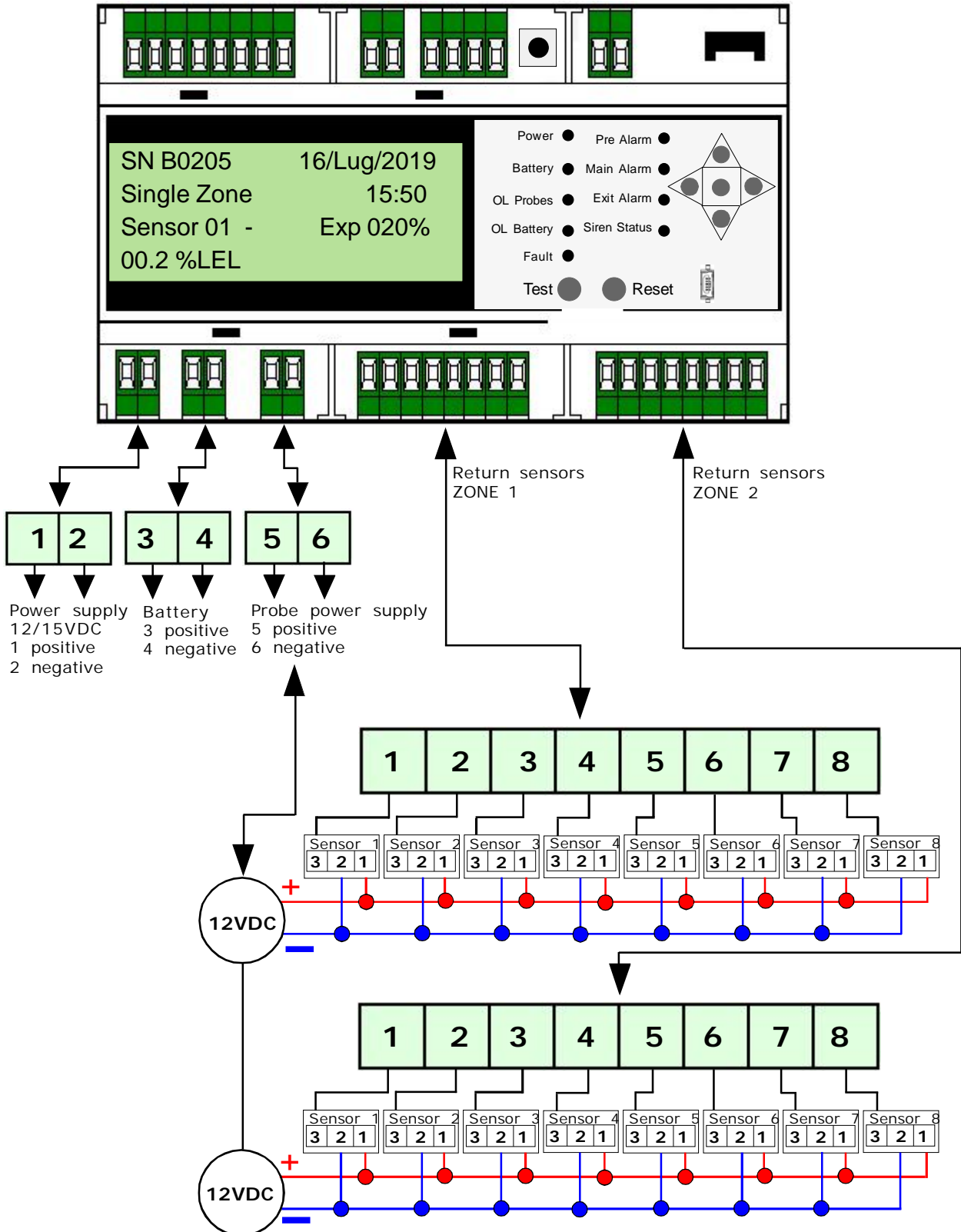

Electrical connection of some equipment  
service 110/240 VAC 50/60 Hz

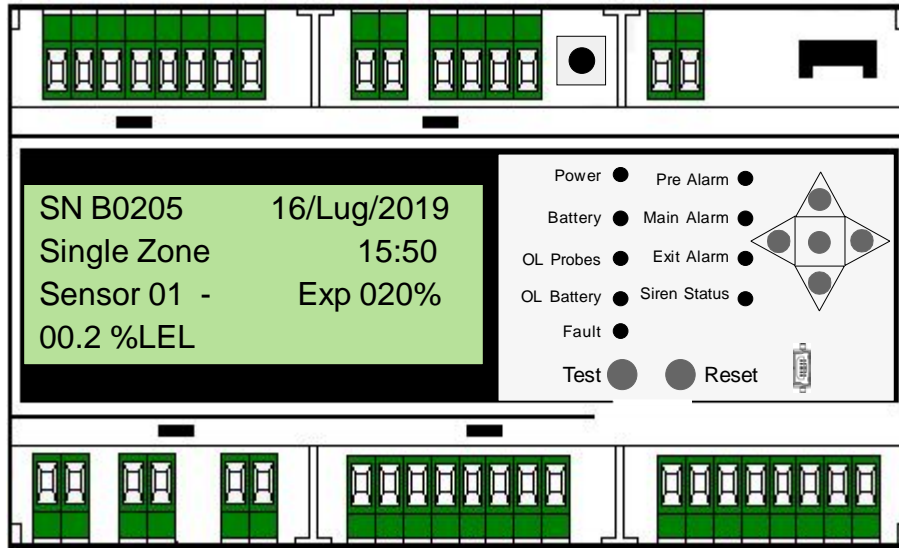

**NOTE!**

All relays are voltage free

==== Connections of a Normally Closed Solenoid Valve without Positive Safety inserted =====

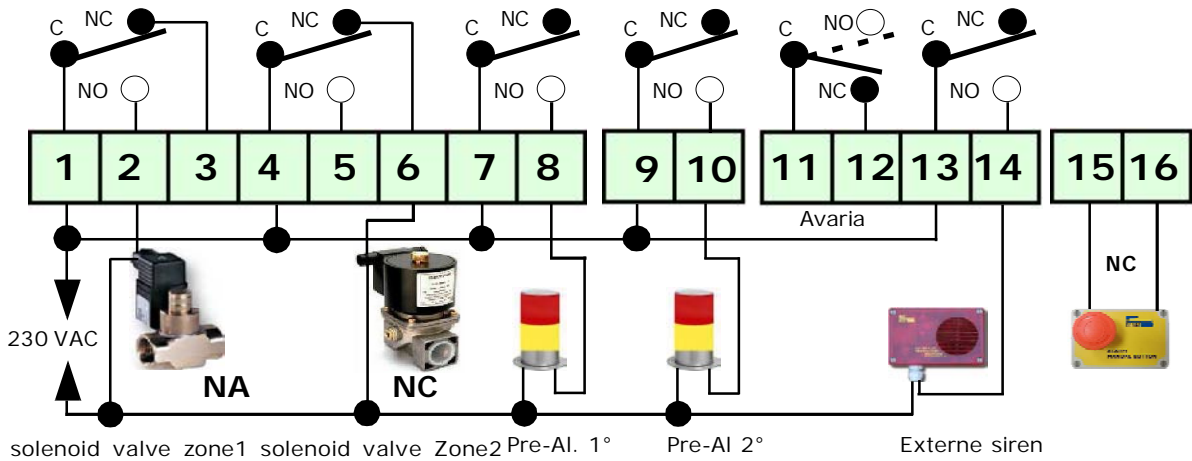

==== Normally Closed Solenoid Connections with Positive Safety =====

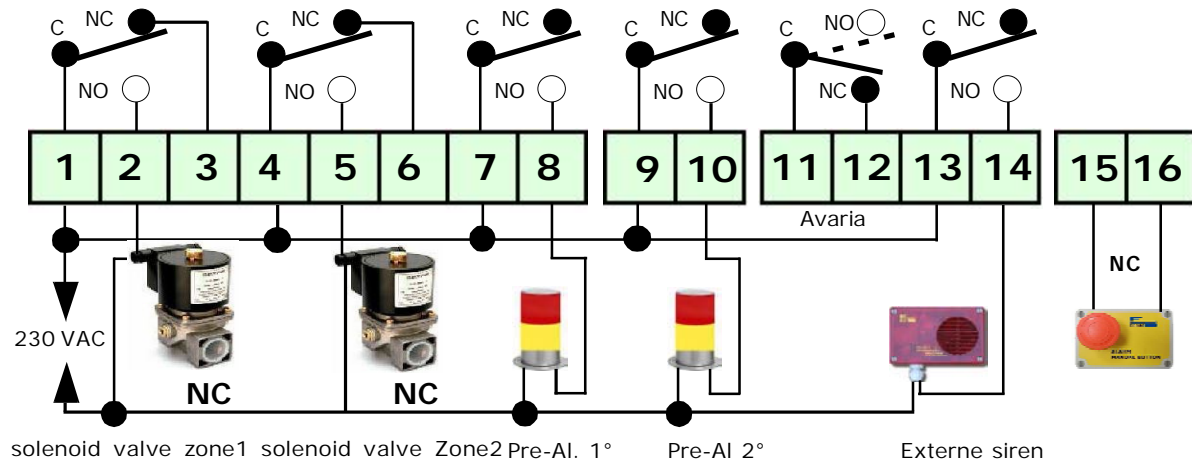

Electrical connection Expansion card

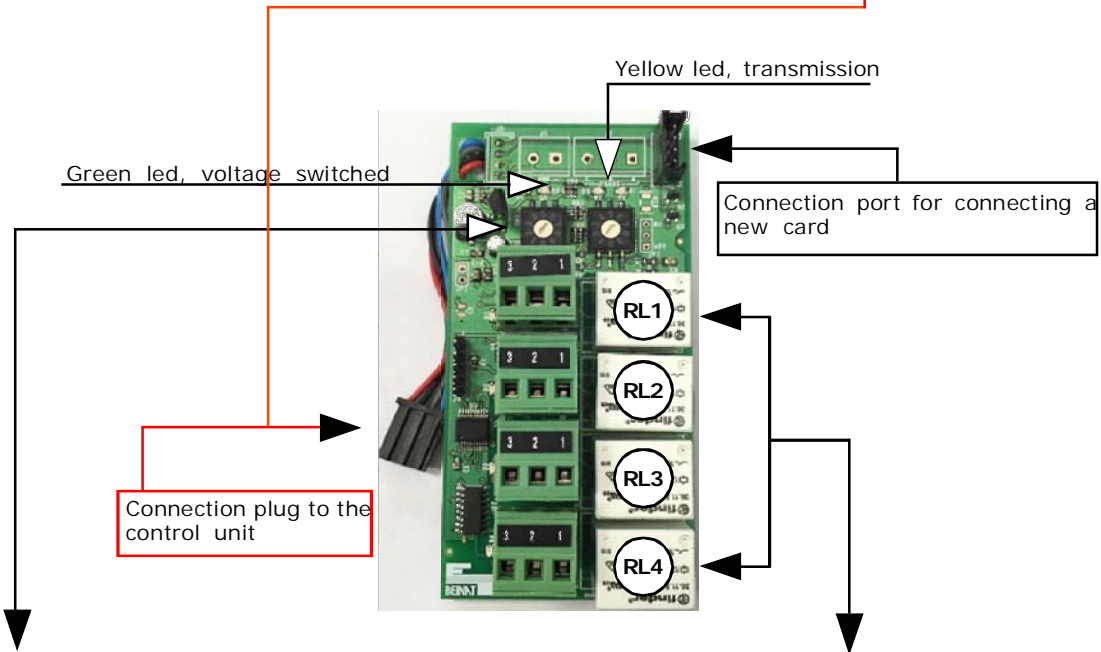
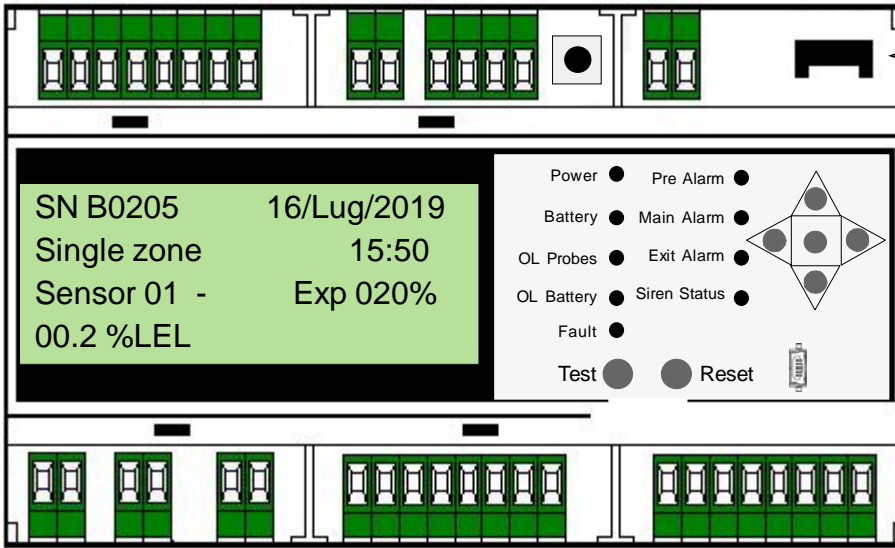

**Each connected board must have an address unique to avoid conflicts in the data transmission.**  
 To enter the addresses of each **CARD-RLS4** you have to act through the rotary switches that each **CARD** possesses, with them you can select the desired address from 1 to 16



**Tens**



**Unit**

**Example to select an address**  
 Turn the Switch of tenths until you find the desired tenth. For example: **0**  
 Turn the Switch of units until you find the desired unit. For example: **6**  
**In this way you will set the address " 6 "**

**Each relay can be coupled to the selected probe and now you can match all the functions you want**

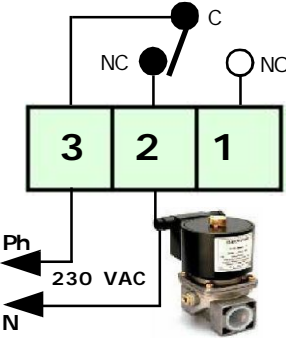

**EV NC 230 VAC**

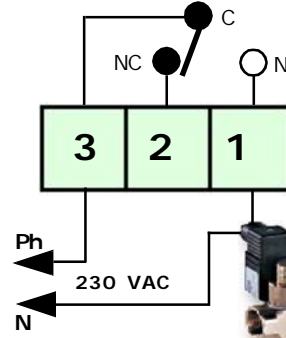

**EV NA 230 VAC**

**Note!**  
 All relays are voltage free.  
 Capacity Contacts **10A 230VDC resistive**



Electrical connection to the mains voltage 110/240 VAC 50/60 Hz by optional cabinet of KAC019



**WARNING.**

Before connecting to the mains power, ensure the voltage is correct. Carefully follow the instructions and the connections according to Regulations in force, keeping in mind that the signal cables should be laid separate from the power cables. An automatic cut-off switch (appropriately identified as device sectioning of the detector) should be incorporated in the electrical system, adequately located and easily accessible.

**Optional cabinet code KAC019 for BX316xp, Degree of protection: IP65 composition:**

- a) Omega bar for BX316xp insertion,
- b) Switching Power Supply 110 ÷ 240 VAC 75/100 W 12 VDC),
- c) Control unit and power supply wiring,
- d) Battery holder bracket

**Dimensions for 1 control unit: 330x340x160**, Dimensions Packaging: 330x380x190, Weight: 3100 grams approx.

**Dimensions for 2 control unit: 340x450x160**, Dimensions Packing: 350x390x190, Weight: 3400 grams approx.

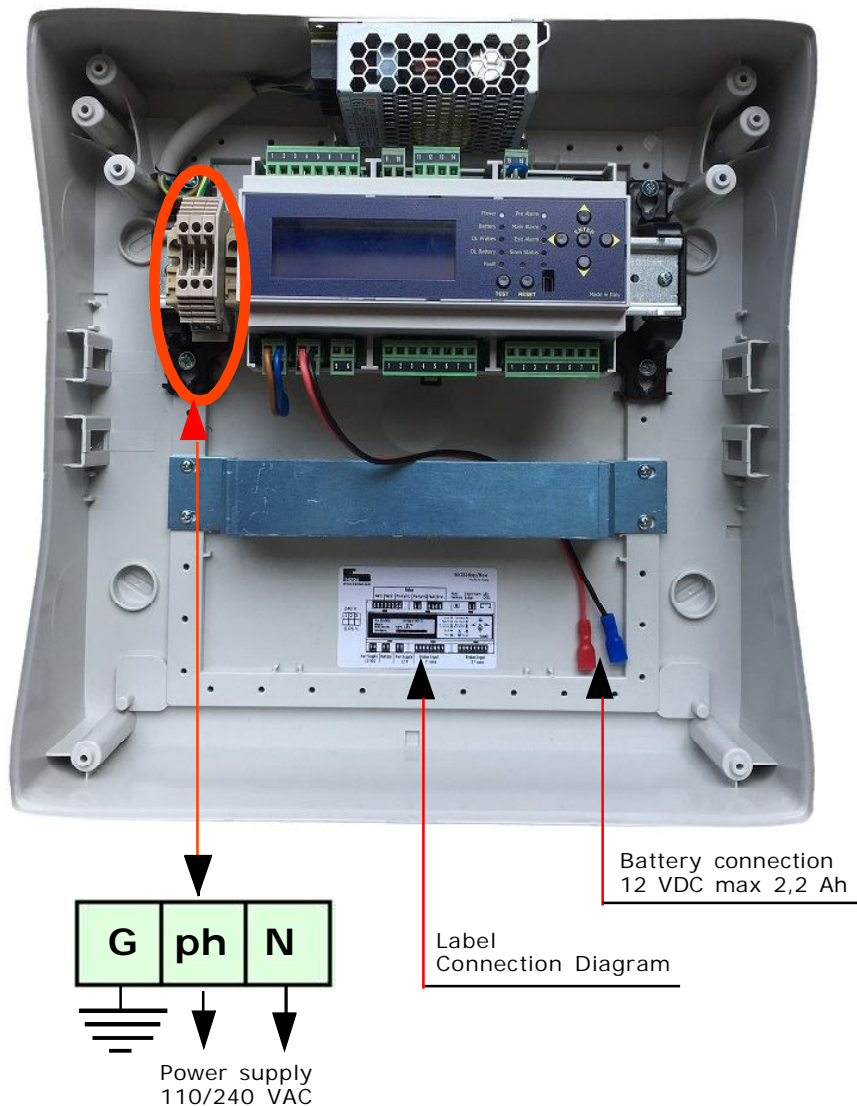

#### Installation and positioning of the control unit

The **BX316xp** control unit belongs to group II and must be installed in a safe area; **Outside the ATEX zone**, however, not in boiler rooms or engine room. The control unit must be accessible and visible to the user.

The **BX316xp** has an Omega Bar enclosure and is a device suitable for mounting on pre-assembled quads and has IP20 protection. powered at **15 VDC**

The **BX316xp / boxed** complete cabinet is an equipment suitable for wall mounting and is powered by **110/240 VAC** with **IP65** protection

When installing, it is good to use the normal care that an electronic equipment requires:

- Install the equipment away from excessive heat sources.
- Avoid liquids coming into contact with the control unit, remembering that its external structure has IP20 degree of protection

**If installed on the Boxed version (cabinet) supplied to the source is IP65.**

**The probes must be selected with an IP degree depending on the area to be controlled (Kitchens, Boiler Rooms, Laboratory, etc.) by selecting one of the probes from Beinat from IP30 to ATEX. see page 3**

#### Installation and positioning of the probe

You can connect many types of remote probes to this unit. Therefore, they should be positioned at different heights depending on the type of gas to be detected.

These heights are:

- **30 cm** from the lowest point of the floor in order to detect: *Heavy gases (L.P.G. etc.)*
- **30 cm** from the highest point of the ceiling in order to detect: *light gases (Methane, etc.)*
- **160 cm** from the lowest point of the floor in order to detect: *volatile gases (CO, etc.)*

**It is important to remember that remote sensors should be installed, bearing in mind that:**

- 1) The sensors should not be placed near the appliances to be controlled (boilers, burners, industrial kitchens, etc.) but on the opposite side.
- 2) The sensors should not be affected by smoke, vapour, and moving air, as they could distort their detection.
- 3) The sensors should not be placed near sources of heat, ventilators or fans.

It should be noted that the internal GAS sensors of the probe are perishable components with a variable average life span from 5 to 6 years (you can request the relative table). Therefore, after this period of time has elapsed it is advisable to replace them.

#### Maintenance

The user periodically (every 6 months), must perform a functional test of the detection system by spraying appropriate test gas towards sensor connected to the **BX316xp** until to obtain the control unit alarm state.

- a) The control of operation and maintenance must be carried at least once a year by specialized technician.
- b) The disposal of the sensors after 5 years from installation must be performed by specialized technician.qualified.

#### PROBE INSTALLATION INFORMATION

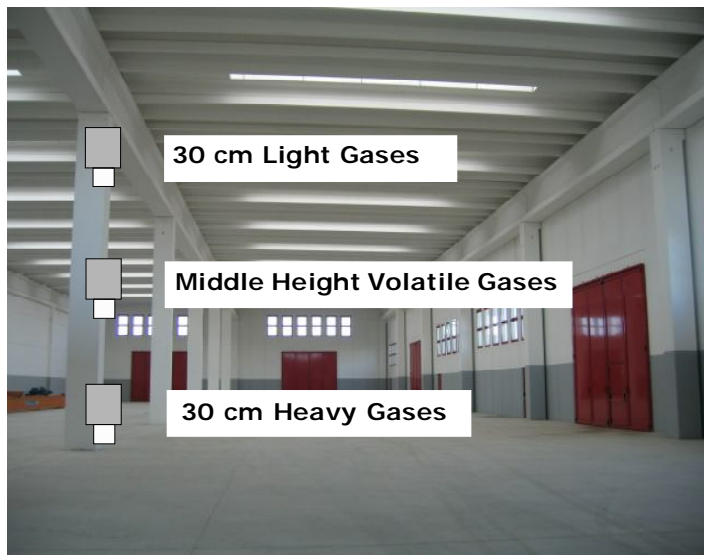

## Turn - on

- 1) Apply power using the proper external switch. This switch should be fitted with protection fuses.
- 2) You will notice that some LEDs will light up in turn for about 20 seconds.
- 3) The display will start the COUNT DOWN of about 90 seconds (warm up). At the end the control unit is ready for detection.
- 4) Pressing and holding down the TEST button, you can obtain a gas leakage simulation. The control unit will carry out the following:
  - It will light up the 13% LEL or the 200ppm (with reference to CO) LED, and the PRE-ALARM LED, switching the 1st threshold relay. The buzzer will issue a low frequency sound.
  - Later, it will light up the 20% L.E.L. or the 300ppm (with reference to CO) LED, the MAIN ALARM LED. In addition to maintaining the PRE-ALARM relay switched, it will also switch the MAIN ALARM relay. The MAIN ALARM LED will start blinking and the buzzer will issue a higher frequency sound.When releasing the TEST button, you will see the opposite: Only the blinking MAIN ALARM and the 20% L.E.L. LEDs will remain ON. When the latching is enabled, the main alarm will continue until the RESET button is pressed, clearing the alarm from the memory.
- 5) To complete the test, carefully read the probe instruction manual and perform the sensor test by issuing gas from a pre-calibrated gas bottle
- 6) If you want to simulate a zone FAULT, you only need to disconnect the return cable of one or all the probes. Reconnect the return cable and press RESET to restore the control unit functioning.

## Before calling a technician, check...

### If the device does not start up.

Check that the power supply is correctly connected at **110/240V**. If powered by the battery, check that the 12Vdc power is correctly connected.

### If the Fault LED lights up.

Check that the connecting cables from the **BX316xp** to the probes are intact, that the probes are properly powered, and that the signal cable is correctly connected.

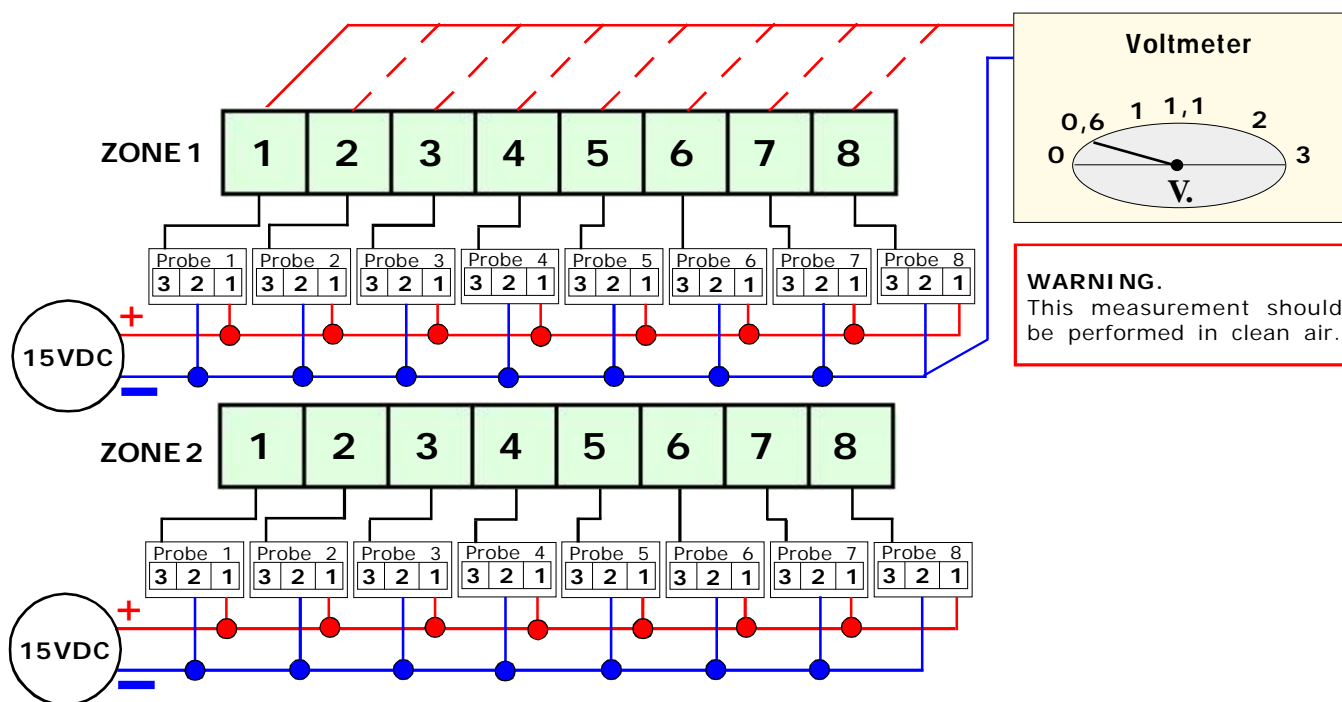

### If the Over Load Probe LED lights up.

Check: that the power polarity has not been inverted, that no short-circuit is present, that the probes were not damaged during installation, that no excessive current absorption is present.

### If the Over Load Battery LED lights up.

Check that the connection cables are not short-circuited, that the polarity has not been inverted, or that the battery is not damaged.

### If the control unit is repeatedly issuing an alarm.

Check that there are no gas leaks. If the alarm signal and the FAULT indicator light turn on together, check the probes.

### If the control unit is issuing an alarm and does not shut off the devices connected to it.

Check that the wiring is correct and that the jumper that carries power to the relay has been set properly. All relays must be free from electrical power. Check the drawing of the connections.

**N.B. All relays are free of voltage.** Controllare il disegno di collegamento.

### If the BX316xp is a solenoid valve connected to 12VDC and is not working well.

**BX316xp** can be connected directly to the solenoid valves, sirens to 12 VDC. with an absorption **maximum of 400 mA**. In case of major absorptions it must use a high power supply.

If other problems arise, a specialised and/or authorised technician and/or the Distributor of **BEINAT S.r.l.** should be contacted directly.

**INSURANCE.** This device is insured by the SOCIETÀ REALE MUTUA for the PRODUCT'S GENERAL LIABILITY up to a maximum of 1,500,000.00 EURO against damages caused by the device in case of failures in functioning.

**WARRANTY.** The warranty term is 3 years from manufacturing date, in agreement with the following conditions. The components acknowledged as faulty will be replaced free of charge, excluding the replacement of plastic or aluminium cases, bags, packing, batteries and technical reports.

The device must arrive free of shipment charges to **BEINAT S.r.l.**

Defects caused by unauthorized personnel tampering, incorrect installation and negligence resulting from phenomena outside normal functioning shall be excluded from the warranty.

**BEINAT S.r.l.** is not liable for possible damage, direct or indirect, to people, animals, or things; from product faults and from its enforced suspension of use.



**DISPOSAL OF OLD ELECTRICAL & ELECTRONIC EQUIPMENT.**

This symbol on the product or its packaging indicates that this product shall not be treated as household waste. Instead, it shall be handed over to the applicable collection point for the recycling of electrical and electronic equipment, such as for example:

- sales points, in case you buy a new and similar product
- local collection points (waste collection center, local recycling center, etc...)

By ensuring this product is disposed of correctly, you will help prevent potential negative consequence for the environment and human health, which could otherwise be caused by inappropriate waste handling of this product. The recycling of materials will help to conserve natural resources. For more detailed information about recycling of this product, please contact your local city office, your household waste disposal service or the shop where you purchased the product.

**Attention:** in some countries of the European Union, the product is not included in the field of application of the National Law that applies the European Directive 2002/96/EC and therefore these countries have no obligation to carry out a separate collection at the "end of life" of the product.



**Control-Unit BX316xp** *Lo styling è della b & b design*

Stamp and signature of the dealer

Date of purchase: .....

Serial number: .....

La Beinat S.r.l. following the purpose of improving its products, reserves the right to change the technical, aesthetic and functional characteristics at any time and without giving any notice.

**BEINAT S.r.l.**  
Via Fatebenefratelli 122/C 10077, S. Maurizio C/se (TO) - ITALY  
Tel. 011.921.04.84 - Fax 011.921.14.77  
[http:// www.beinat.com](http://www.beinat.com)

 **Business** - [info@beinat.com](mailto:info@beinat.com)  
**Help Desk** - [laboratorio@beinat.com](mailto:laboratorio@beinat.com)