

Din omega modular Gas/Fire control unit 4 Conventional zones BX449F v3

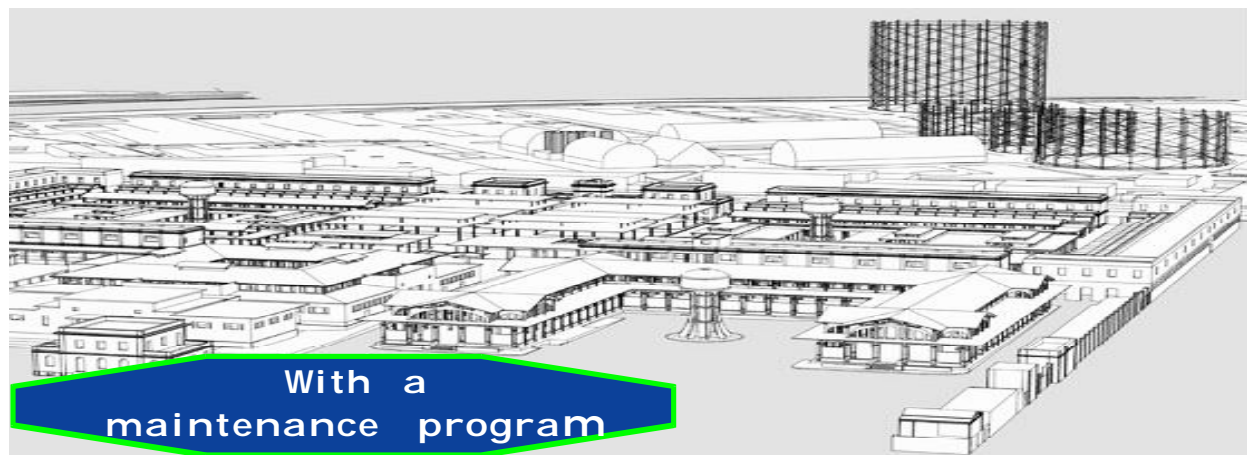

BEINAT S.r.l. always attentive to the needs of the market and new technologies, has overhauled a previous versatile control unit, BX449F, for **GAS and/or FIRE** detection for industrial applications. To which can connect sensors to detect: **Toxic / Explosive Gases, Oxygen, and to detect fire principles.**

Gas detection

The control unit has two danger levels:

1st LEVEL, pre-alarm. This is set at 13% of L.E.L. (200ppm) for all sensors.

2nd LEVEL, main alarm. This is set at 20 % of L.E.L. (300ppm) for all snors.

To facilitate event readings, the control unit has a front panel with 4 LEDs indicating which probe is currently being monitored in rotation, and a display showing the gas concentration measured on each pass.

GAS configurations

Connection from 1 to 4 conventional sensors, for different types of GAS up to **max 4 sensors**, 1 for each zone.

Fire detection

To the **BX449F** you can connect up to 5 fire detectors per each zone, either temperature or optical smoke detectors, through a balanced line:

Optical smoke detectors, Temperature, Velocimetric temperature

The control unit's microprocessor checks the detectors and connection line efficiency, open or short-circuited.

When the sensors detect a fire, theyl switch the proper relay.

FIRE configurations

Each zone can be connected up to a **Max 5 sensors**, even mixed, Smoke or Temperature, for a total Max of 20. Automatic recognition of the type of probe connected, be it GAS OR FIRE.

Configurations Mixed GAS FIRE

For **each zone assigned**, the detection of only GAS or FIRE can be connected without distinction

OXYGEN configurations

When the operation is selected to detect OXYGEN, **other types of sensor cannot be connected.**

OXYGEN ALARM for <Oxygen deficiency and> Oxygen Excess

For oxygen pre-alarm and main alarm levels, see references on page 5.

Maintenance TEST.

With special measures, the function can be enabled to exclude the alarm relay for a maximum duration of 60 minutes. This allows the technician to perform all functions without having to interrupt the gas flow or activate sirens



Important: Assembly / maintenance of the appliance must be carried out by qualified personnel and in accordance with applicable laws and regulations.

The manufacturer assumes no responsibility for the use of products that have to comply with particular environmental and / or installation standards.



Important note

Before connecting the equipment, it is recommended that you read the instruction manual carefully and keep it for future reference. It is also recommended to perform the electrical connections correctly as per enclosed drawings, observing the instructions and the Standards.

N.B. Refer to the documentation in all cases where the symbol is on the side



**Installation
and user guide**



**INSTALL IN SAFE
AREA, NO ATEX**

CONFORMITY



EN 50270
EN 45544-1-3
EN 61010-1

Conforme EN 60079-29-1
Reports issued by Eurofin Italia

Precautions

CHECK the integrity of the unit after having removed it from the box.

Check that the data written on the box correspond to the type of gas used.

When doing the electrical connections, follow the drawing closely.

Any use of the detector for purposes other than the intended one is considered improper, and as a result of which **BEINAT S.r.l.** therefore disclaims any responsibility for possible damages caused to people, animals or objects.

IMPORTANT: the functional test must not be carried out with the gas tap open as this does not guarantee sufficient concentration to activate the main alarm.

TERMS and EXPECTATIONS: The installation of the **BX449F** control unit, its ordinary and extraordinary maintenance, every six months, and its out of service removal at the end of the functional life guaranteed by the manufacturer, must be carried out by **authorized or specialized personnel**.

Do not allow it to become wet.

The unit can be seriously damaged as it is not waterproof so when immersed in water or exposed to high humidity levels.

Do not drop it.

Heavy knocks or falls during transportation or installation can damage the appliance.



Technical Specifications

Main power	110/240VAC 50/60Hz \pm 10%
Insulation	Class II
Secondary Power Through Battery Max 2,2 Ah (Optional)	12 V \pm 10%
Battery charger max. 2.2 Ah	Controlled
Power demand	11W max. 230 VAC
Power demand	6W max. @ 12 VDC
Range of the contacts on the gas pre-alarm, alarm and fault relay	10A 250 VAC resistive
Range of the contacts on the fire alarm relay	10A 250 VAC resistive
Detection	
Pre alarm	13% of L.E.L. or 200 ppm for CO
Final alarm	Set to 20% of L.E.L. or 300 ppm for CO
The LEL is calculated for Gas Methane	5000 ppm = 5% V/V
Data refresh	2 ms
OXYGEN alarm	<Oxygen deficiency,> Excess Oxygen
Monitored events	Through backlit color display
Zones	4
Number of connectable gas sensors	4 (1 for each zone)
Types of conventional gas sensors	Semiconductor, Catalytic, Electrochemical cell, Pellistor
Number of connectable fire sensors	20 (5 for each zone)
Types of fire sensors connectable	Optical smoke - fixed temperature - increment temperature
Micro-switches to include or exclude the gas sensors, Exclusion only for CO	1 for each zone
Microswitches to select the OXYGEN detection	incorporated
Microswitches to display	Over Range and Under Range
Type of faults detected by fault circuit	Interruption, short circuit, or wear
OVER LOAD Check	1 for each sensor
OVER LOAD Check	1 for battery
Input signal GAS	4 \pm 20 mA on 220 Ohm
Input signal FIRE	2.2 VDC at rest, 8.7VDC in alarm, 13.92 VDC with short-circuited cables
Functioning temperature	-10°C \pm +60°C
Waiting, blinking time (warm-up)	About 2 minutes
Manual test	Built in
Max. distance between sensors and unit	100 m
Max. distance between battery and unit	0,5 m
Cable diameter to connect the sensors	1 mm ²
Connection: The cable of connection of the sensor must not be installed together with the power cables.	
Otherwise, make sure to use a shielded cable	
Omega-type size DIN EN 50092 9 modules	158*90*58
Degree of protection	IP20

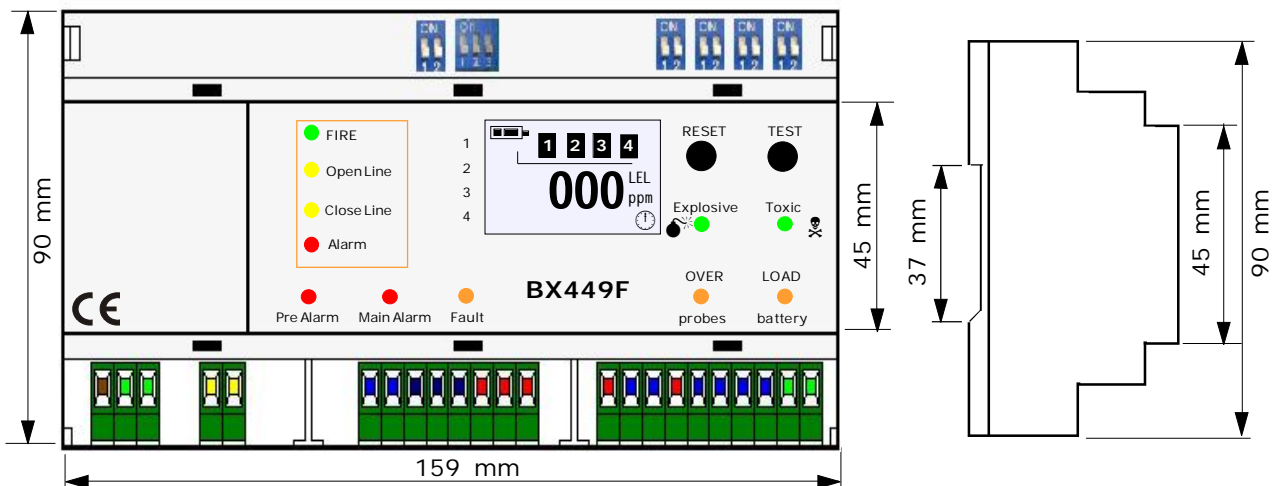

Probe	Sensor	Degree Protec.	Suitable for Zone	Gas Detected	Range Working	Output	Precis.	Calibration Automatic	Relay
SG500	Catalytic	IP30	Domestic Use	CH4-LPG	0÷100% LEL	4÷20 mA	±5 %	N O	N O
SG544	Catalytic	IP44	Tertiary	CH4-LPG	0÷100% LEL	4÷20 mA	±5 %	N O	N O
SGM595	Catalytic	IP55	Tertiary	See catalogue	0÷100% LEL	4÷20 mA	±5 %	Yes	N O
SGM595/A	Catalytic	IP66	Zone 2	See catalogue	0÷100% LEL	4÷20 mA	±5 %	Yes	N O
SGM533	Catalytic	IP55	Tertiary	See catalogue	0÷100% LEL	4÷20 mA	±5 %	Yes	Yes
SG800	Catalytic	IP66	Zone 2	See catalogue	0÷100% LEL	4÷20 mA	±5 %	Yes	Yes
HCF100	SemiConduct	IP55	Tertiary	FREON	0÷300% ppm	4÷20 mA	±5 %	N O	Yes
SG895	Pellistor	ATEX	Zone 1	See catalogue	0÷100% LEL	4÷20 mA	±5 %	Yes	N O
SG580	Catalytic	IP66	Zone 2	See catalogue	0÷100% LEL	4÷20 mA	±5 %	Yes	N O
SGF100	Catalytic	IP64	Zone 2	Methane	0÷100% LEL	4÷20 mA	±5 %	Yes	Yes
SGF102	Catalytic	IP64	Zone 2	LPG	0÷100% LEL	4÷20 mA	±5 %	Yes	Yes
SGF104	OpticalFluores	IP64	Zone 2	Oxygen	In %	4÷20 mA	±5 %	Yes	Yes
SGF106	SemiConduct	IP64	Zone 2	FREON	0÷300% ppm	4÷20 mA	±5 %	Yes	Yes
SGF108	Electrochemical	IP64	Zone 2	H2S	0÷300% ppm	4÷20 mA	±5 %	Yes	Yes
SGF110	Electrochemical	IP64	Zone 2	C O	0÷300% ppm	4÷20 mA	±5 %	Yes	Yes
SGF112	Catalytic	IP64	Zone 2	Hydrogen	0÷100% LEL	4÷20 mA	±5 %	Yes	Yes
CO100r	Electrochemical	IP55	Tertiary	C O	0÷300% ppm	4÷20 mA	±5 %	Yes	Yes
CO100Ar	Electrochemical	IP66	Zone 2	C O	0÷300% ppm	4÷20 mA	±5 %	Yes	Yes
SG800 ^{duct}	Catalytic	IP66	Zone 2	CH4LPG	0÷100% LEL	4÷20 mA	±5 %	Yes	Yes
CO200 ^{duct}	Electrochemical	IP66	Zone 2	C O	0÷300% ppm	4÷20 mA	±5 %	Yes	Yes

FIRE DETECTORS

RF500 Optical Smoke Detection - ECO **EC500** Series Optical Smoke Detection

RF570 Fixed Temperature Detection at 70 ° C - ECO **EC500** Series Fixed Temperature Detection at 70 ° C

RF540 Increased Temperature Detection - ECO **EC540** Series Increased Temperature Detection -

ZF300 Universal socket - Series ECO **ZFC200** universal socket - Series ECO **ZFRC250** Universal socket with relay

Application in:

Domestic: family accommodation. Local boilers up to 70 kW-h

Tertiary Areas: Large Rooms Boilers, Workshops, Material Deposits, Industrial Kitchens, Large Buildings, Buildings.

Zone 2 - Mixed IP66 ATEX: High probability of escape, high risk locations, premises for which applicable regulations apply.

Zone 1 - Hazardous Area, High Risk Hazards, Rooms for Which Regulations, Tanks, Control Valves are in force.

WARNING! Actions to be taken in case of alarm

Gas

- 1) Put out all free flames.
- 2) Close the main gas tap or the LPG cylinder tap.
- 3) Do not turn any lights on or off; do not turn on any electrical device or appliance.
- 4) Open windows and doors in order to increase ventilation.

If the alarm stops, its cause must be found and the relevant consequent measures taken.

If the alarm continues and the cause of gas presence cannot be found or removed, abandon the building and call the emergency services when outside (fire department, distributors, etc.)

IMPORTANT: Iproof operation should not be carried out with the gas tap since this does not guarantee a sufficient concentration to activate the alarm.



Fire

*Keep calm

*Open the windows and request assistance

*Do not turn lights on or off, do not operate electrically powered equipment and devices

*If possible, press the nearest emergency button.

*If possible use the nearest fire extinguisher, do not use foam extinguishers or water near electrical devices or directly on switchboards.

*If the fire developed in an environment, get out, closing the door.

*If the fire is in another room and the smoke makes impracticable stairs and corridors, close well the doors and try to seal fissures using possibly wet cloths.

*If the smoke makes breathing difficult, filter the air through a handkerchief, (better if wetted), lie on the floor (the smoke tends to rise to the top).

*If the alarm stops, is necessary to identify the cause that provoked and act accordingly.

*If the fire continues and the cause is not vacate the building and abandon the building and call the emergency services when outside



The installation of the detector does not exempt from the compliance with all regulations concerning the characteristics, installation and use of gas appliances. The ventilation of the spaces and the elimination of combustion products are described in the UNI norms according to ART. 3 LAW 1083 / 71 and relevant legal provisions.

Control unit from 1 to 4 conventional sensors BX449F Rev. 3

Instruction manual

{a} OVERVIEW

- Power supply 110/240 VAC
- Controls up to 4 remote sensors, referred to **Gas**
- Manages explosive and toxic gases.
- Controls up to 20 remote sensors, referred to **Fire**
- Manages smoke and temperature sensors
- Manual alarm managed by remote button
- Various possibilities of parameter configuration
- Status indications with LED
- Output signals in alarm supplied via 2 relays, referred to gas
- Output signals in alarm supplied via 1 relay, referred to fire
- Fault output signals supplied via 1 relay, referred to gas and fire
- wall support 6 DIN modules.
- Conforms to the operating regulations EN60079-29-1

{b} GENERAL DESCRIPTION

The BX449F is a control unit capable to control the concentration of gas up to 4 input channels, each of which can be connected via a 4-20 mA communication to a toxic or explosive gas detection/measurement device. The control unit is built with the following I/O interfaces.

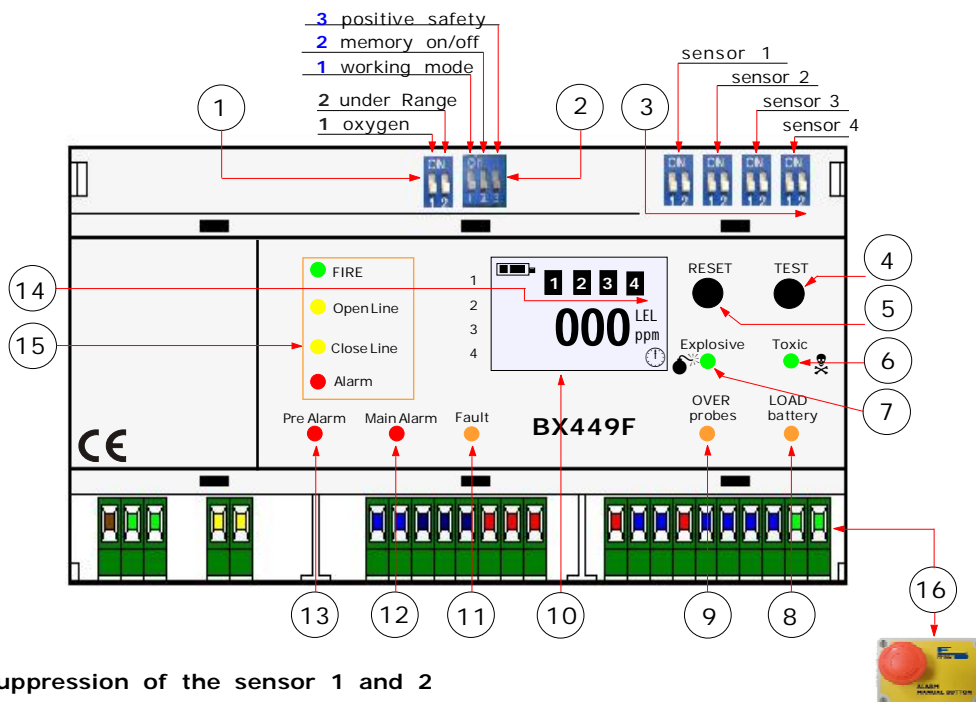

CH of the deadband suppression of the sensor 1 and 2

1) Group of two switches.

DIP-SWITCH 1. Used to enable the OXYGEN DETECTION. **ON** ENABLED, **OFF** DISABLED.

In this condition the display turns blue and the LEDs (6 and 7) "Explosive and Toxic" turn off. **OTHER TYPES OF DETECTION ARE NOT POSSIBLE**

DIP-SWITCH 2. Used to enable the deadband zone suppression for all sensors

Setting this two switch ON or OFF it is possible to enable or disable the suppression of the signaling of any under range in the input signal at the corresponding input.

Instead, over ranges will always be reported.

The condition is signaled by the flashing of the "Explosive Gas" LED of the corresponding input. (7)

In this case, pressing the "TEST" button you will see that the detection starts at minus 29 ppm.

2) Group of three switches.

DIP-SWITCH 1. RELAY MODE. Used to select the relay working mode: **Continuous** or **Pulsed**

ON: PULSED - OFF: CONTINUOUS.

DIP-SWITCH 2. MEMORY LOG. Used to enable or disable memory logging.

ON ENABLED, **OFF** DISABLED. Warning! It is possible to disable the function only for the toxic gas detection

DIP-SWITCH 3. POSITIVE SAFETY. Used to select positive safety.

ON ENABLED, **OFF** DISABLED.

3) Group of four double switches to select sensor and type of gas.

DIP-SWITCH 1. Sensor 1 - DIP-SWITCH 2. Sensor 2 - DIP-SWITCH 3. Sensor 3 - DIP-SWITCH 4. Sensor 4

Setting the first switch of each group to ON or OFF enables or disables the corresponding input. Setting the second switch of each group to ON or OFF switches to detect from explosive gas to toxic. Depending on the type of gas, appears on the display **LEL** for explosive gases or **ppm** for toxic gas and the corresponding LEDs light up (6/7)

WARNING! When a sensor is excluded, all the memories will be restored.

4) TEST BUTTON, to check the operation of the entire system, EXPLOSIVE Gas

Press the "TEST" button and its displays the progressive increase of the **% of the LEL** followed by the number of the monitored sensor.



When the **13% of LEL** of the pre-alarm is reached, the display changes color to red, the preset relay switches its status and the buzzer emits an intermittent low-frequency sound, the corresponding LED (13) lights up and the sensor number stays for a few seconds.

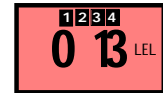

Continuing to keep the button pressed, the % of gas increases up to the **20% of LEL** of the main alarm, the preset relay switches its status and the buzzer emits an intermittent high frequency sound, the corresponding LED lights up (12) and the sensor number stays for a few seconds.



Keeping pressed the button of the % of the **LEL** will go up until you reach the Over range **FAULT** Releasing the "TEST" button turns off the lights and stops the acoustic alarm



4) TEST BUTTON, to check the operation of the entire system, TOXIC Gas

Press the "TEST" button its displays the progressive increase in the **ppm** followed by the number of the monitored sensor.



When the pre-alarm of **200 ppm** is reached, the display changes color to red, the preset relay switches its status and the buzzer emits an intermittent low frequency sound, the corresponding LED (13) lights up and the sensor number stays for a few seconds.



Keeping the button pressed, the in **ppm** increases until it reaches the main alarm of **300 ppm**, the preset relay switches its status and the buzzer emits an intermittent high frequency sound, the corresponding LED (12) lights up and the number of the sensor stays for a few seconds.



Continuing to hold the % in ppm button increases until reaching the Over Range **FAULT** Releasing the "TEST" button turns off the lights and stops the acoustic alarm

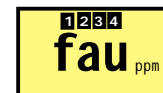

4) TEST BUTTON, to check the operation of the entire system, OXYGEN Gas

Press the "TEST" button the **control unit starts in alarm on the red Display appears 00.0** and you see the progressive increase **of% of oxygen**, followed by the number of the monitored sensor.



When the pre-alarm of **19.5% of oxygen** is reached, the preset relay switches its status and the buzzer emits an intermittent low frequency sound.



Continuing to keep the button pressed, the oxygen percentage increases up to the percentage of oxygen **20.9%**; Ideal percentage for a civil environment.



When **22.5% is reached, it enters the pre-alarm condition**, the preset relay switches its status and the buzzer emits an intermittent low frequency sound.



When **23.5% is reached, it enters the alarm condition**, the preset relay switches its status and the buzzer emits an intermittent high frequency sound.



Keeping the TEST button pressed, the % of the LEL increases until it reaches the Over Range **FAULT**

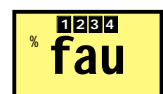

Releasing the "TEST" button turns off the lights and stops the acoustic alarm

5) RESET BUTTON

A "RESET" button allow the user to cancel the events that occurred and are contained in the memory by an intentional manual reset action.

Warning!

Pressing the RESET button once only resets the alarm and fault memories.

Pressing three times in succession restarts the entire system.

6) TOXIC GAS LED selection .

Turning on, this LED indicates that the corresponding input is configured to detect toxic gases.

7) EXPLOSIVE GAS LED selection .

Turning on, this LED indicates that the corresponding input is configured to detect explosive gases.

WARNING! The flashing of this LED can also indicate the presence of under/over range entering the corresponding input.

8) LED OVERLOAD BATTERY

This LED lights up when there is a short circuit or excessive absorption in the backup battery supply lines.

9) LED OVERLOAD SENSOR

This LED lights up when there is a short circuit or excessive absorption in the sensor supply lines.

10) Color backlit display to control all functions.

a) The battery icon turn on when the **BX449F** is powered by an external battery.

The battery icon also indicates the charge status of the battery , when itflashes the battery is low.

b) The **% symbol** on the display is reserved for oxygen detection.

c) The numbers indicate the detected gas concentration or mean some warnings.

d) The **numbers from 1 to 4** represent the sensors. These light up every 2 seconds.

e) The **ppm** turn on when the sensor is detecting **toxic gas**.

f) The **LEL** turn on when the sensor is detecting **explosive gas**.

g) The clock, the timing icon turns on when the control unit is in the Warm up phase, the display starts the count down.

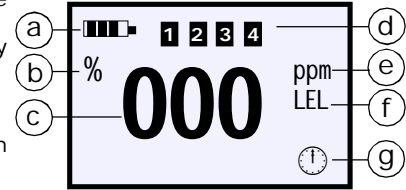

11) FAULT LED. This LED blinks when one of the connected sensors is faulty, if there is an interruption in the cable connection, or if an error was made during wiring.

The sensor can be identified by reading on display the number from 1 to 4.

When this LED is on, the device is no longer capable of detecting, and stops.

To reactivate the device, the damaged probe must be repaired or disabled using the internal micro-switch, and then the RESET button must be pressed. (See chapter on page 6)

12) LED MAIN ALARM

This LED starts to flash when the gas concentration level reaches the main alarm threshold (20% LEL for explosive gases, 300 ppm for toxic gases).

This signal is the "latching" type and maintains its status until the "RESET" button is pressed, for compatibility with the current performance standards.

13) LED PRE-ALARM

This LED lights up when the gas concentration level reaches the second pre-alarm threshold (13% LEL for explosive gases, 200 ppm for toxic gases).

This signal is the "auto-reset" type.

14) SENSORS. **1 2 3 4** This number represents the gas sensor connected from 1 to 4.

===== FIRE =====

15) Section reserved for Fire detection.

The BX449F , in addition to detecting various gas types, is also built for fire detection
 Up to 5 fire detectors can be connected to each zone via a balanced line up to a maximum of 20 detectors,
Smoke optics, Temperature, Velocimetric temperature
 The microprocessor of the control unit controls both the efficiency of the detectors and the connection line, open or short-circuited.
 If necessary in case of fire or fault by switching the appropriate relay.

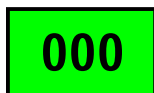

Normal condition
 The display with color green, represents an absence of fire detection



Alarm condition
 The display with red color represents a fire alarm. Check from the display in which area



Fault condition
 The display shows that the connection line is open, or that the sensor is fault

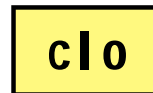

Fault condition
 The display shows that the connection line is short-circuited or that the sensor is fault

16) External manual alarm button.

The control unit is designed to be connected to a manual alarm button. Pressing the button the control unit will go directly into alarm even when it is in programming or warm up status; Closing all the auxiliaries connected to it. When pressed, BTN appears on the display and turns red.



- **FAULT RELAY:** this "latching" relay switches when there is an error signal from the connected sensor (see image below).
- **PRE-ALARM RELAY:** this "autoreset" relay switches when the detected gas concentration exceeds the second pre-alarm threshold.
- **MAIN ALARM RELAY:** this "memory" relay switches when the detected gas concentration exceeds the main alarm threshold.



WARNING!

All relay outputs of the control unit are voltage free. The maximum range of such contacts is specified in the next chapters.

{c} OPERATING INSTALLATION INSTRUCTIONS



WARNING!

The installation parameters modification must be performed by qualified personnel. Be sure to disconnect the controller from the power supply before making changes to the connections.

ELECTRICAL CONNECTION

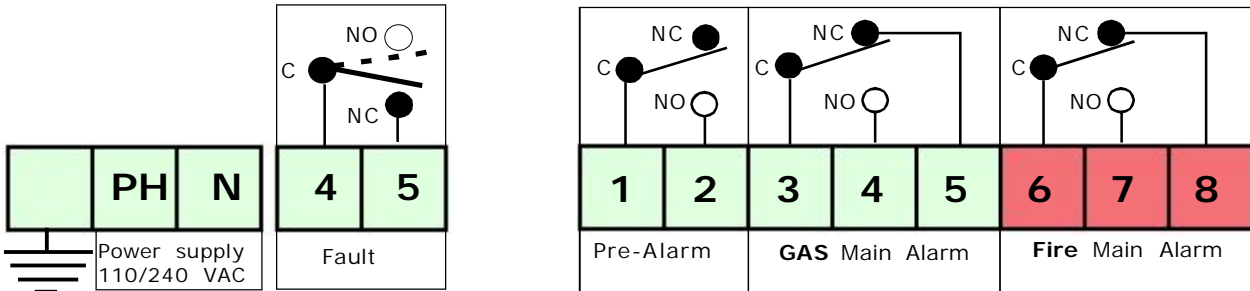

- Terminals 1, 2 and 3: Main power supply
- Terminals 4 and 5: Fault relay contacts

- Terminals 1 and 2: GAS pre-alarm threshold relay contacts
- Terminals 3,4 and 5: GAS main alarm relay contacts
- Terminals 6, 7 and 8: Main alarm relay contacts

- a) Connect terminal 1 to ground, terminal 2 to phase, terminal 3 to neutral.
- b) Power the system only when all the parameters have been configured.
- c) Connect the desired utilities to the output relays described above according to your needs. Then connect the sensors and the battery (optional) to the signal terminal block.

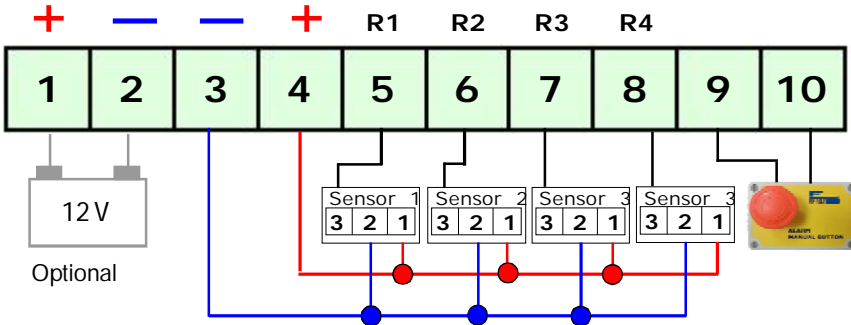

The signal terminal block for the **GAS detection** (previous figure) is composed as follows:

- Terminals 1 and 2: Optional back-up battery connection.
- Terminals 3 and 4: Sensor power supply. The voltage is generated by the control panel.
- Terminals 5, 6, 7 and 8: Connection return signal of 4-20 mA GAS sensors.
- Terminals 9 and 10: Connection of the optional manual alarm button.

WARNING! The optional battery is charged directly by the control unit. This control unit can connect a maximum of 4 sensors. Each conforms to the 4-20 mA current loop system on this terminal block. Connect the sensors as shown in the figure.

FIRE DETECTORS SERIES "NORMAL"

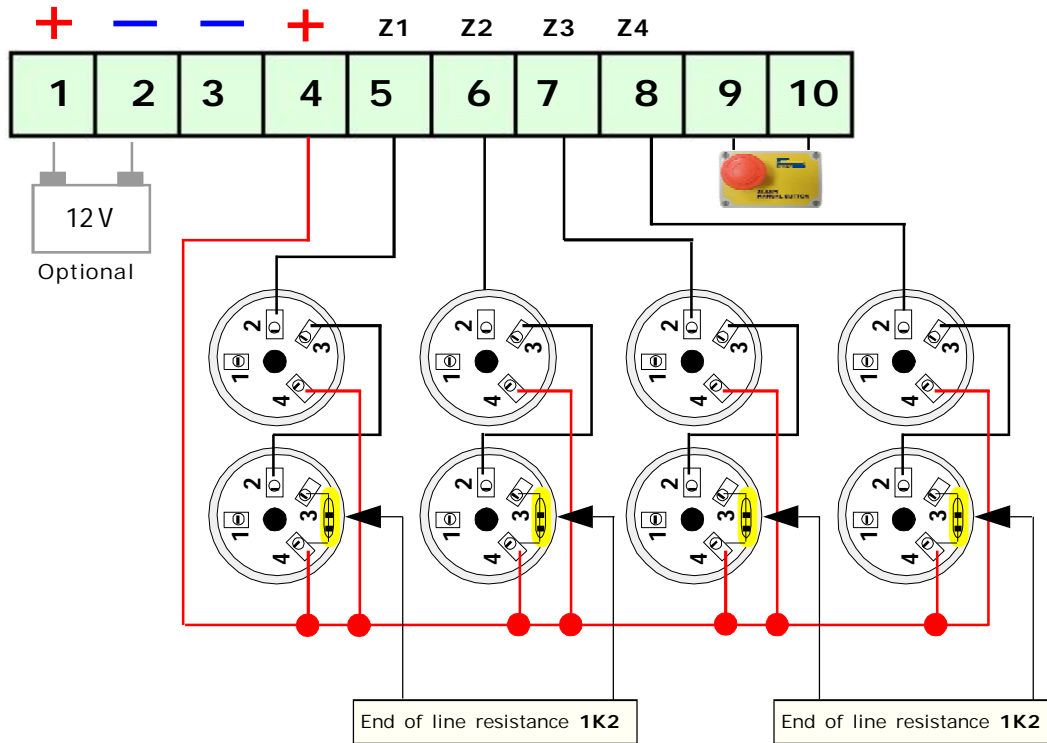

FIRE DETECTORS SERIES "ECO"

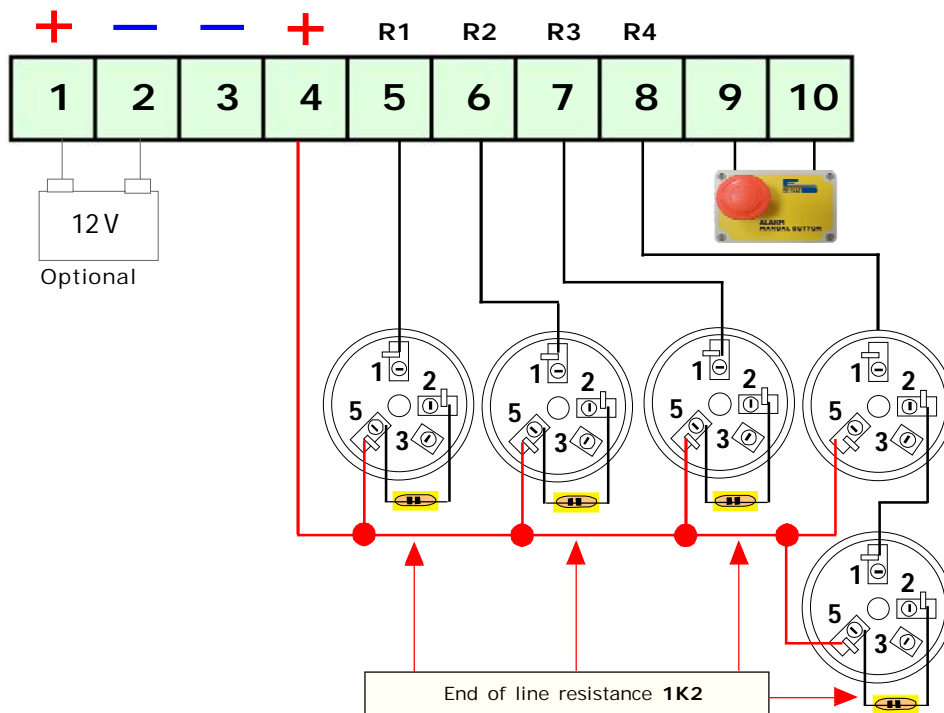

The signal terminal block for the **FIRE detection** (previous figure) is composed as follows:

- **Terminal 1 and 2:** Optional back-up battery connection.
- **Terminal 4:** Positive detector power supply. The voltage is generated by the control unit.
- **Terminals 5, 6, 7 and 8:** Connection of fire detectors return signal
- **Terminals 9 and 10:** Connection of the optional manual alarm button.

WARNING! The optional battery is charged directly by the control unit. This control unit can connect a maximum of 5 fire detectors for each zone. Each conforms to the 4-20 mA current loop system on this terminal block. Remember to set the **end of line resistance from 1K2**

ACTIVATION AND DEACTIVATION OF THE SENSORS

Through Micro switches on the control unit can enable or disable the 4 Zones.

You can connect up to **4 sensors GAS** (1 for each zone)

Or, you can connect up to **20 FIRE detectors** (5 for each zone)

Mixed connections Gas Fire

In the configuration Mixed Gas Fire every single zone can be connected indistinctly with:

only GAS

only FIRE.

The recognition of the gas or fire detectors takes place automatically

N.B. The microswitches are also used for disabling the sensor in case of fault.

Micro-switches **(1)** to enable or to disable the sensors.

Position **ON** enabled - Position **OFF** disabled

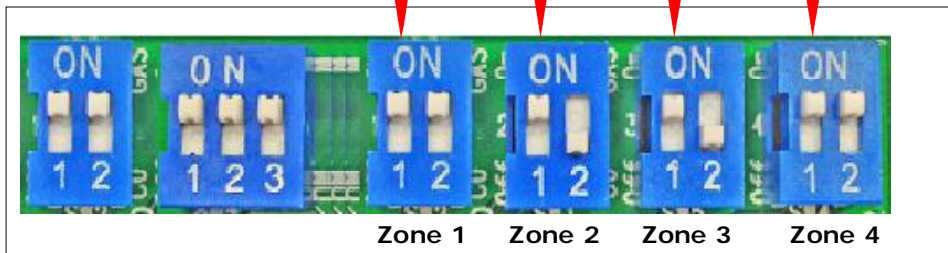

Selection of the type of gas monitored by each probe

The **BX449F** is fitted with four micro-switches in order to select the type of gas that the connected probes should monitor.

The LEL **explosive gas** reading is obtained by shifting the switch to **ON**.

The ppm **toxic gas** reading will be obtained by shifting the switch to **OFF**.

SELECTION OF THE TYPE OF GAS MONITORED BY EACH PROBE

The **BX449F** is fitted with four micro-switches in order to select the type of gas that the connected probes should monitor.

The LEL **explosive gas** reading is obtained by shifting the switch to **ON**.

The ppm **toxic gas** reading will be obtained by shifting the switch to **OFF**.

Micro-switches **(2)** to select the type of gas monitored

Position **ON** reading in LEL - **Explosive gas**

Position **OFF** reading in ppm - **Toxic gas**

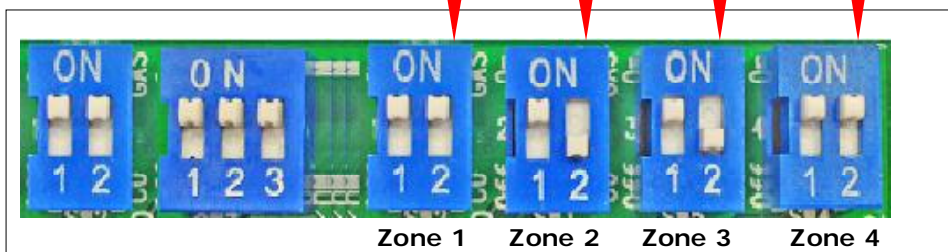

Switch 1 - the main alarm relay Working Mode.

In the **ON** (impulse) position, the relay remains closed for 3 seconds, and then disenergizes afterwards.
In the **OFF** (continuous) position, the relay remains closed until the **RESET** button is pressed.

Switch 2 – Alarm logging maintenance, reserved for toxic gases

By setting the micro-switch to **ON**, the device **WILL LOG** the alarm, maintain the relay closed, and the main alarm LED will blink, until the **RESET** button is pressed.

By setting the micro-switch to **OFF**, the device **WILL NOT MAINTAIN** the alarm memory and the relay switches off when the connected sensor no longer detects gas.

IN COMPLIANCE WITH STANDARDS EN 60079-29-1 | THIS FUNCTION IS ENABLED ONLY when you select **the toxic gas detection** reading in "ppm"

Switch 3 – Selection of the positive safety

In the **ON** position, the positive safety function is **ENABLED**.

In the **OFF** position, the positive safety function is **DISABLED**..

Micro-switches **1** Working mode of the Main alarm relay
Micro-switches **2** Alarm memory logging referred to co
Micro-switches **3** Positive Safety

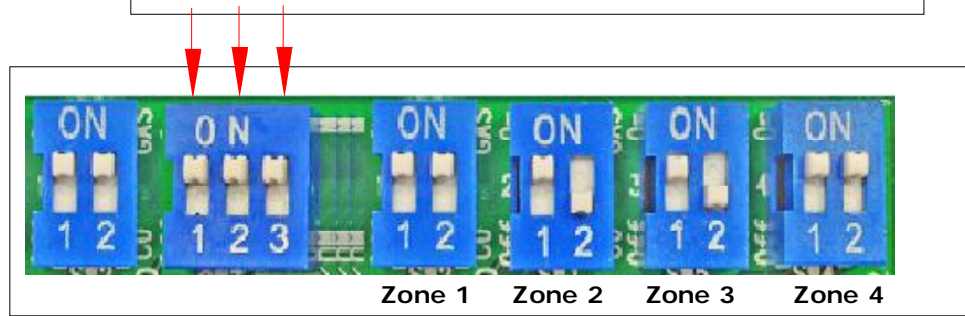

Switch 1 - detection selection only for OXYGEN

ON: The detection function for oxygen is enabled; This function applies to all 4 zones

OFF: The detection function for oxygen is disabled

Switch 2 - Exclusion or disabling of the neutral range

ON: the under range reading is **enabled**

OFF: the under range reading is **disabled**

Microswitches **1** only OXYGEN operating selection
Microswitches **2** Exclusion or disabling the neutral range

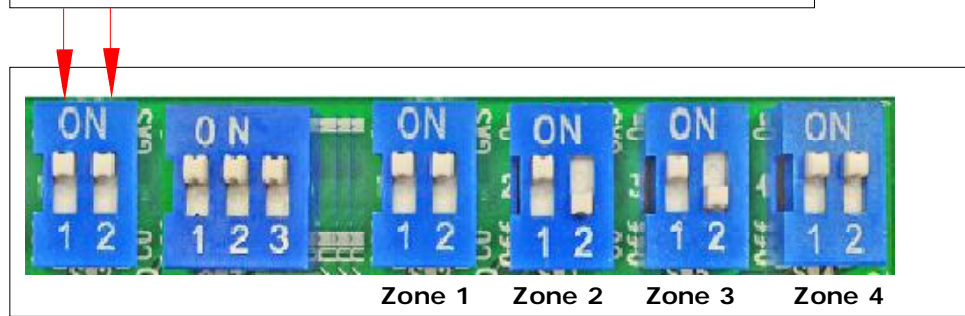

After making all the connections and configurations, the system can be powered



WARNING!

- > This control unit is NOT built for installation in ATEX classified areas
- > To meet the requirements as a control unit according to the standard EN 60079-29-1: 2016, the DIP switches on the control unit must be set to: SW2.1: ON, SW2.2: OFF, SW3.2: ON, SW4.2: ON.
- > All the wiring of the remote sensors must be made using wires with a minimum section of 1.5 mm² and no longer than 25 m. Do not use the same conduit for signal and power cables.
- > In case of installation in the presence of strong EMC disturbances, the shielded cables use is strongly recommended. The screen must be connected to the 'Gnd' terminal of the interested area only on the side of the control unit.
- > The appliance must be connected to the power supply by means of a switch capable of disconnecting the poles in compliance with current safety standards and with a contact separation of at least 3 mm in all poles.
- > The installation and electrical connections of this appliance must be carried out by qualified technicians and in compliance with the current technical and safety standards.
- > Be sure to turn off the power before wiring the device.
- > Safety depends on the installer (whose responsibility is to set up a detection system in compliance with existing standards, both European and national) to choose the correct type of loads to be connected to the control unit and the correct configuration of the system parameters. In case of doubt, please contact the distributor.

{d} OPERATIONAL LIMITATION

01. This device can be set for explosive, toxic gases and fire
02. For transverse sensitivities refer to the remote sensor user manual.
03. Response time T₉₀: 1 second *
04. Temperature operating range: -10° C ÷ + 60° C
05. Humidity operating range: 0 ÷ 90% RH not condensed
06. Pressure operating range: 800 ÷ 1100 hPa
07. Power supply: 110/230VAC 50/60Hz
08. Absorption: 11W
09. Electrical wiring: see paragraph (c)
10. Batteries: max 2,2 Ah
11. Sample scope: Not applicable
12. Warm-up time: 100 seconds
13. Stabilisation time: not applicable
14. Contact rating: 10A 250V
15. Pre-alarm range 1st interval: for explosive gases set at 8% of LEL for toxic gases set at 120 ppm
16. Pre-alarm range 2nd interval: for explosive gases set at 13% of LEL for toxic gases set at 200 ppm
17. Alarm range 1s threshold: for explosive gases set at 20% LEL for toxic gases set at 300 ppm
18. Protective rating: IP20
19. Weight: 260 g
20. ATEX protection: this device must be installed in NON-CLASSIFIED ATEX areas.

* The response time of the entire system is determined by the response time of all parts of the equipment within the gas detection system.
The maximum delay time of a special status in case of transmission errors until insertion.

{f} TEST

Once activated, the control unit starts warm up for 100 seconds.
In this phase all the LEDs flash, waiting for the connected probes to go into full speed.
The power LED flashes until the warmup done.

Once started, the control unit enters detection mode: the power LED is on, even with the LEDs of the type of gas selected on the zones enabled, based on the configuration of the DIP-SWITCHES.

It is therefore possible to carry out a first check of the system by pressing the test button: keeping this button pressed, the control unit simulates a concentration of gas gradually increasing from the enabled sensors, and it is therefore possible to control the switching on and off of the LEDs and that all switch relay, enabling the loads connected to them.

{g} WORKING CONDITIONS

Depending on the input signal of the remote sensors, the control units can be found in the following working condition:
NORMAL MODE: the control unit receives a signal from the sensors corresponding to a gas level between 0% and 8% of LEL for explosive gases and between 0 ppm and 120 ppm for toxic gases.

The relays are off and no alarm or fault LED lights up. The buzzer is off.

1st PRE-ALARM: the control unit receives a signal from the sensors corresponding to a gas level between 8% and 13% of LEL for explosive gases and between 120 ppm and 200 ppm for toxic gases.

The relays are off and the red "8/120" LED lights up. The buzzer is off.

2nd PRE-ALARM: the control unit receives a signal from the sensors corresponding to a gas level between 13% and 20% of LEL for explosive gases and between 200 ppm and 300 ppm for toxic gases.

The pre-alarm relay changes state and the red LED "13/200" and "pre-alarm" also lights up

The pre-alarm relay is energized. The buzzer is on (low frequency).

MAIN ALARM: the control unit receives a signal from the sensors corresponding to a gas level higher than 20% of LEL for explosive gases and greater than 300 ppm for toxic gases.

The main alarm relay changes state and the red "20/300" LED also lights up, the "Main alarm" LED flashes. The main alarm relay is energized. The buzzer is on (high frequency).

OVER/UNDER RANGE: the control unit receives an under/over range signal. This condition is signaled through two different flashing frequencies of the explosive gas LEDs.

The relays are off and no alarm or fault LED lights up. The buzzer is off.

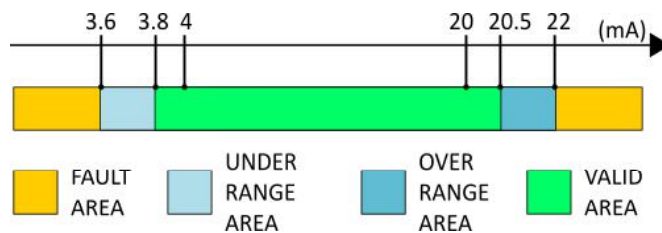

FAULT: the control unit receives a "short circuit" or "open circuit" signal.

The yellow fault LEDs are on. The fault relay is energized. The buzzer is on (fixed sound).

SYSTEM ERROR: the control unit is blocked due to an internal fatal error.

The yellow error LEDs flash. Relays are OFF. The buzzer is on (LED frequency).

{h} TROUBLESHOOTING

Problem.

If the error LED lights up, the system reports an error status.

Possible cause: The input current loop is broken or the transmitter is not powered.

Solution:

Check the connections between the transmitter and the control unit for interruptions. Check with a multimeter the presence of a voltage around 12 VDC between the "+ V" and "GND" terminals of the reference input.

{i} PERIODIC CONTROL

MAINTENANCE

A periodic service must include the following operations:

a) (every 6 months): Check the correct operation of the detection system by applying calibrated gas to each remote sensor and checking the value.

Refer to the user manual of the sensors for more information.

b) (every 12 months): revision of the control unit transfer function and correct detection of anomalous situations.

This can be done by disconnecting the sensors and forcing through a suitable calibrator the input current of each zone to the significant values for example:

- 0 mA: open circuit,
- 3,7 mA: under range,
- 4-20mA: normal operation,
- 21 mA: Over range
- 23 mA: fault.

The following figure shows the conversion between mA and the corresponding gas concentration.

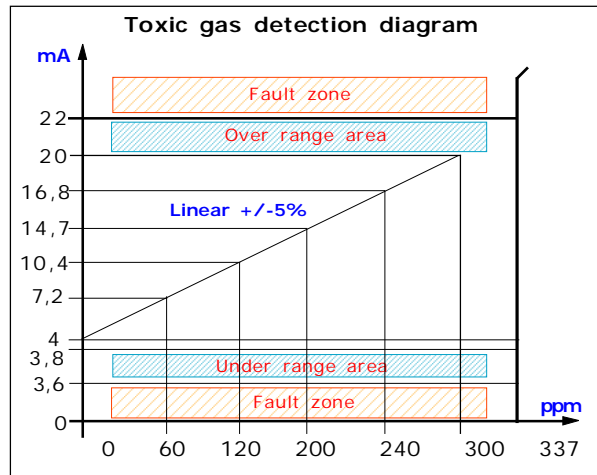
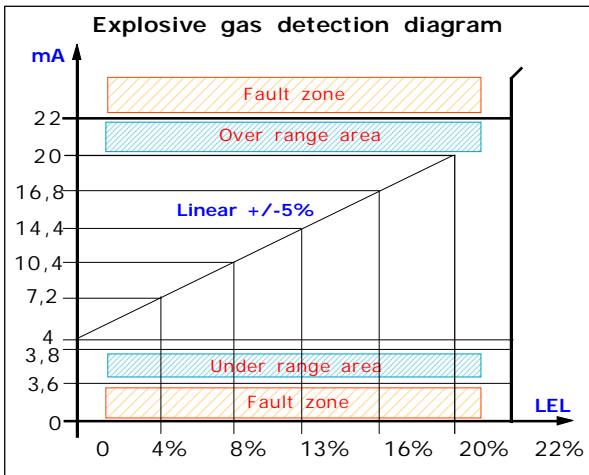

Programma di Manutenzione

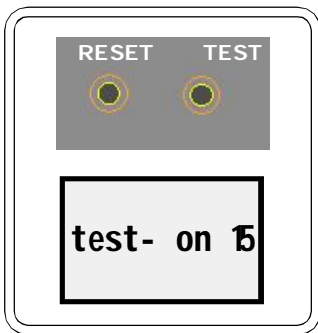

The simultaneous and prolonged pressing for 5 seconds of the "TEST" and "RESET" keys enables the test-on mode in which the control unit does not switch the general alarm relay for a period of 15 minutes; Not even by pressing the external manual button. A further press of the keys in the same mode extends the time by 15 minutes up to a maximum of 60 minutes.

In this mode, the string "tEst-On" (scrolling) is displayed before each passage from the current channel to the next, followed by the minutes of the general alarm relay being decommissioned.

N.B. Once the pre-set minutes are reached, the control unit automatically returns to the control service mode.

You can terminate this mode before resetting the control unit by pressing 3 consecutive times and within 5 seconds the **RESET** button

NOTE. The alarm is activated only with the external manual button.



Functional test with GAS Pre-Calibrated and control tester

The user periodically at least every 6 months, must carry out a verification of the functioning of the system by spraying a special test gas at the base of the connected probes until obtaining the alarm status.

At least once a year

A more accurate check must be carried out by a specialized technician who must issue the verification certificate with the **Beinat TS1008 tester**.

The decommissioning of the system must be carried out by a specialized technician.

{j} STORAGE

Temperature operating range: -10° C to + 60° C
Humidity operating range: 0 ÷ 90% RH not condensed
Pressure operating range: 800 ÷ 1100 hPa

{k} CONTAMINANTS

Not applicable to the control unit. For the remote sensor, refer to the remote sensor user manual

{l} AUTOMATIC RESET

The pre-alarm relay state is automatically reset when the concentration drops below the pre-alarm threshold. On the contrary, the alarm relay state CANNOT be automatically reset and remains in memory until the control unit is reset by the user. Refer to the section for details.

{m} BATTERY MAINTENANCE

This control unit is equipped with input terminals (1 and 2) for backup of the external 12 VDC power supply. The control unit charges the battery up to 1.2 Ah. Battery maintenance operations must be based on the manufacturer's technical information.

{n} SPARE PARTS

This control unit has not user serviceable parts.

{o} ACCESSORIES

This control unit has not compatible accessories.

{p} WARRANTY

With a view to the constant development of its products, the manufacturer reserves the right to modify technical data and functions without prior notice.

The consumer is guaranteed for any lack of conformity pursuant to European Directive 1999/44 / EC, as well as to the manufacturer's document about the warranty policy.

The full text of guarantee is available on request from the seller.

{q} MARKING

Example of a label



{r} INSTALLATION EXAMPLES

ELECTRICAL CONNECTIONS



WARNING.

Before connecting to the mains power, ensure the voltage is correct. Carefully follow the instructions and the connections according to Regulations in force, keeping in mind that the signal cables should be laid separate from the power cables. An automatic cut-off switch appropriately identified should be incorporated in the electrical system, adequately located and easily accessible.

NOTE!

All relays are voltage free

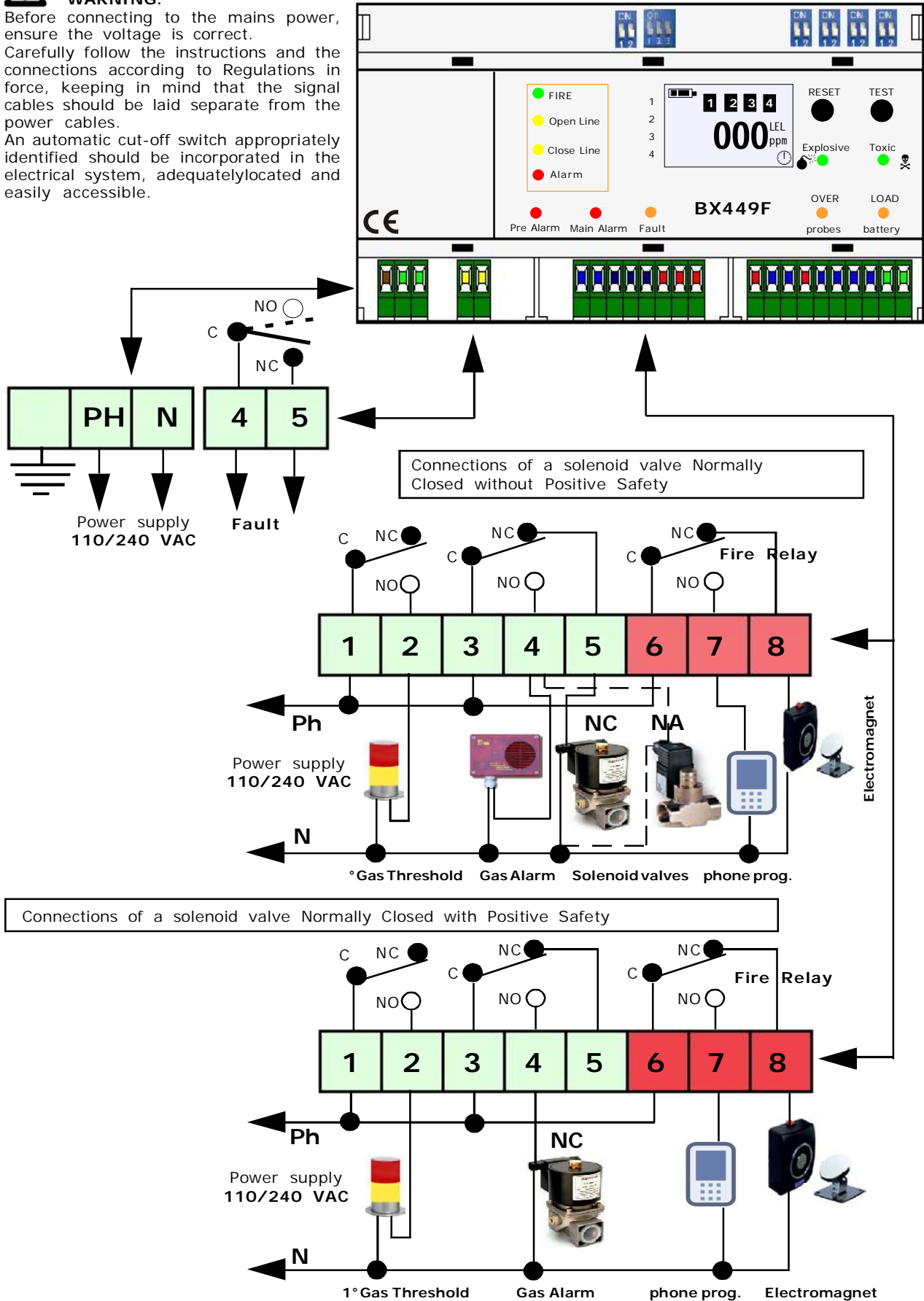

Sensors terminal block for GAS detection

In this diagram they are connected three probes GAS and one of fire.

N.B. at each input you can connect: 1 GAS sensor, 1 Group sensors fire from 1 to 5 max

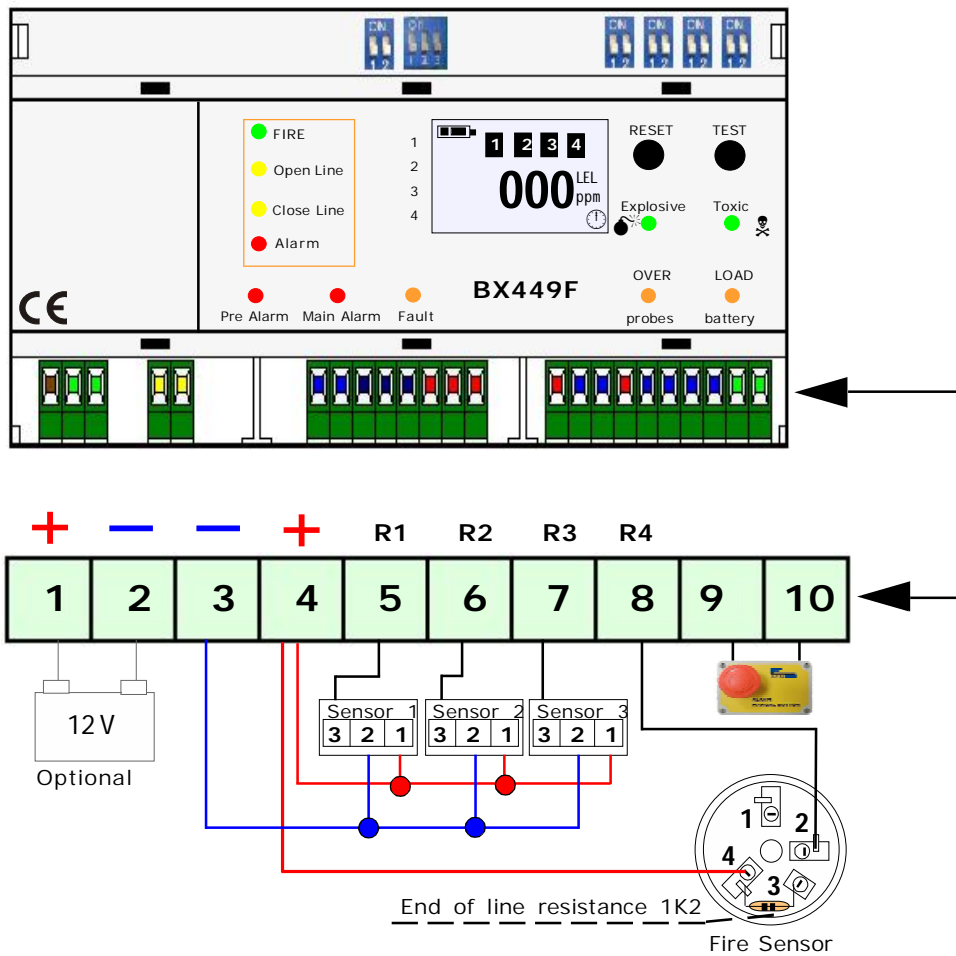

Connections of a solenoid valve normally closed without Positive Safety and auxiliary to 12VDC through a power Switching

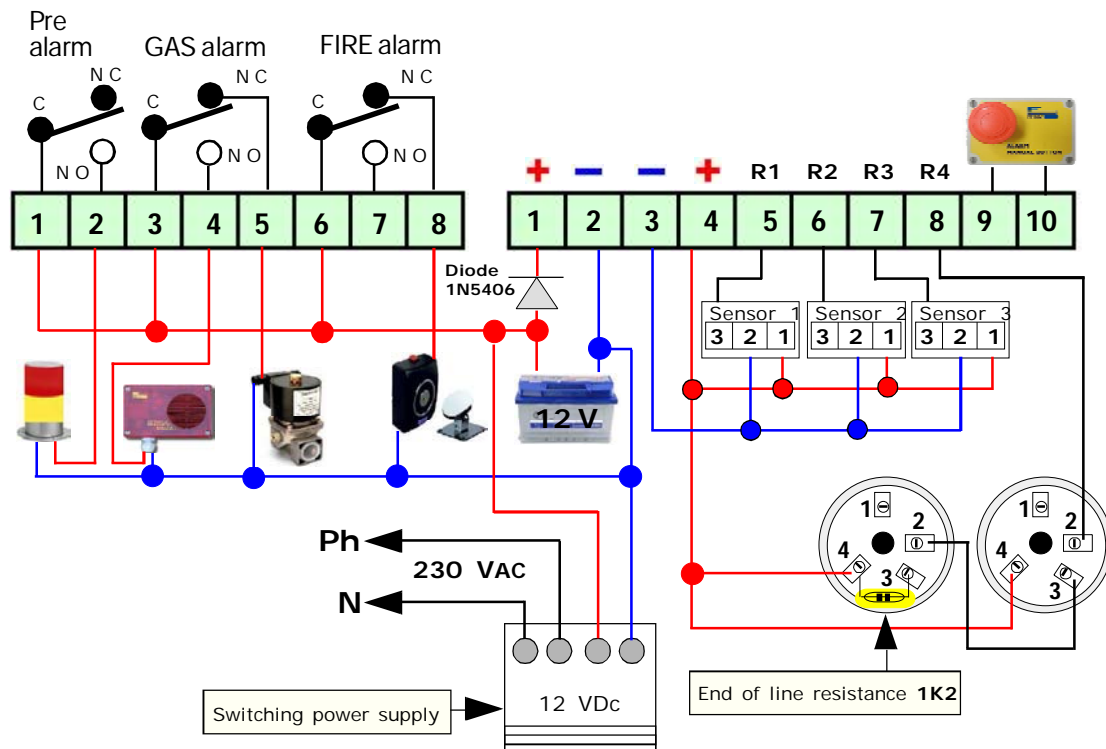

Installing and positioning the control unit

The BX449F control unit belongs to group II and must be installed in a safe area; **Outside the ATEX zone**, however, not in boiler rooms or engine room. The control unit must be accessible and visible to the user.

The BX449F control unit is a device suitable for being installed on the wall, or on an electrical panel using the special bracket, optional, on request.

When installing, it is good to use the normal care that an electronic equipment requires:

- Install the equipment away from excessive heat sources.
- Avoid liquids coming into contact with the control unit, remembering that its external structure has IP20 degree of protection if installed on the Boxed version (cabinet) supplied to the source is IP....

Installing and positioning the sensors

The sensors must be selected with an IP degree depending on the area to be controlled (Kitchens, Boiler Rooms, Laboratory, etc.) by selecting one of the probes from Beinat from IP30 to ATEX. see page 3

The GAS connected sensors to this equipment are of multiple types and must be positioned at different heights according to the type of gas to be detected.

These heights are:

- 30 cm from the lowest point of the floor in order to detect: **Heavy gases (L.P.G. etc.)**
- 30 cm from the highest point of the ceiling in order to detect: **light gases (Methane, etc.)**
- 160 cm from the lowest point of the floor in order to detect: **volatile gases (CO, etc.)**

It is important to note that the remote probes should be installed according to the following restrictions:

- 1) The sensors **should not be placed** near the appliances to be controlled (boilers, burners, industrial kitchens, etc.) but on the opposite side.
- 2) The sensors should not be affected by smoke, vapour, and moving air, as they could distort their measurement.
- 3) The sensors **should not be placed** near sources of heat, ventilators or fans.

It should be noted that the internal GAS sensors of the probe are perishable components with a variable average life span from 5 to 6 years (you can request the relative table). Therefore, after this period of time has elapsed it is advisable to replace them.

Maintenance

The user periodically (every 6 months) must carry out a check of the functioning of the detection system by spraying a special test gas pouring the sensors connected to the **BX449F** until obtaining the alarm status of the control unit.

- a) At least once a year have a more accurate check performed by a specialized technician.
- b) The disposal of the sensors after 5 years from installation must be carried out by qualified personnel.

GAS PROBE INSTALLATION

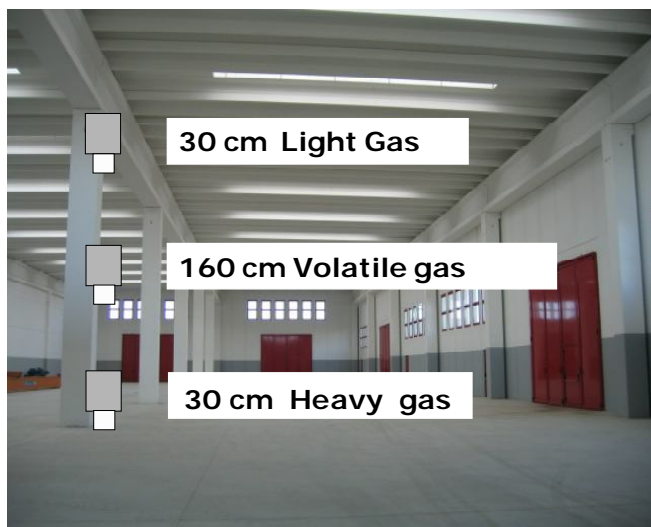

FIRE PROBE INSTALLATION

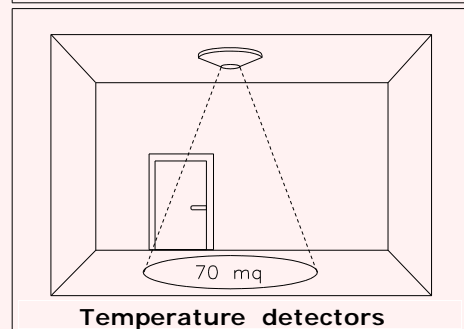
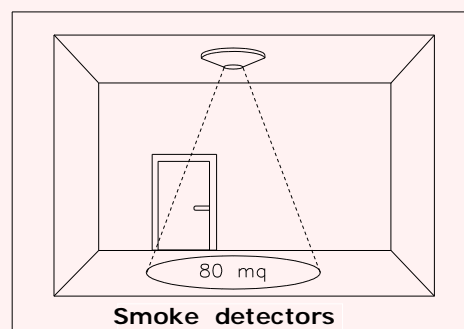

Turn On

- 1) Apply power using the proper external switch. This switch should be fitted with protection fuses.
 - 2) You will notice that some LEDs will light up in turn for about 20". **N.B.** Make sure all leds are working.
 - 3) The display will start the COUNT DOWN of about 90 seconds (warm up). At the end the control unit is ready for detection.
 - 4) Pressing and holding down the TEST button, you can obtain a gas leakage simulation. The control unit will carry out the following:
 - a) It will light up the **prealarm led** set to 13% LEL or the 200ppm (with reference to CO) and switching the 1st threshold relay. The buzzer will issue a low frequency sound.
 - b) It will light up the **main alarm led** set to 20% LEL or the 300ppm (with reference to CO). In addition to maintaining the PRE ALARM relay switched, it will also switch the MAIN ALARM relay. The MAIN ALARM LED will start blinking and the buzzer will issue a higher frequency sound.
 - 5) To complete the test, carefully read the probe instruction manual and perform the sensor test by issuing gas from a pre-calibrated aerosol.
 - 6) If you want to simulate a zone **FAULT**, you only need to disconnect the signal cable of one or all the four sensors. The control unit will carry out the following:
 - The FAULT and MAIN ALARM LEDs will light up and blink;
 - The buzzer will issue a continuous sound;
 - The FAULT and MAIN ALARM relays will switch.
- Reconnect the signal cable and press RESET to restore the control unit functioning.

Troubleshooting and solutions before calling a technician



If the device does not start up.

Check that the 230VAC mains power is correctly connected. If powered by the battery, check that the 12VDC power is correctly connected.

-If the Fault LED lights up.

Check that the probe cables are connected as in the drawing, they have not pinched the insulating sheath. Check that the voltage at the terminals 3-4, is greater than 11 VDC and less than 25 VDC

Check that at the terminals 3 and 5 (6-7-8) is present a voltage from a minimum of 0,8 VDC at a maximum of 1,1 VDC

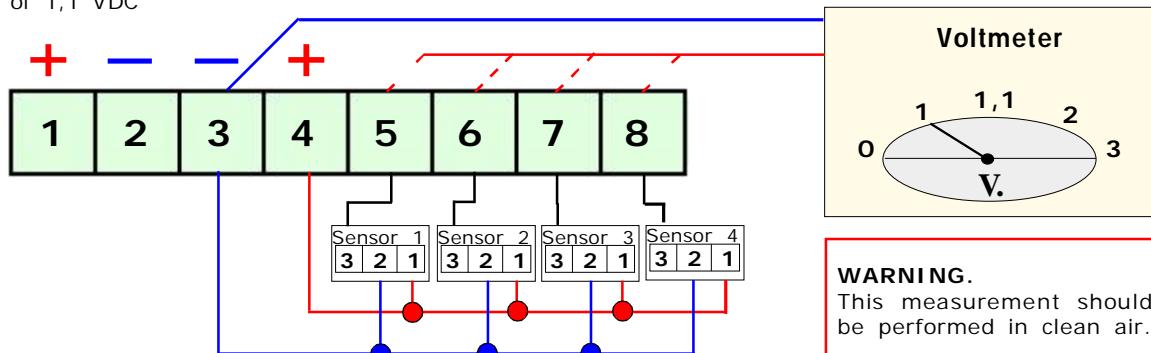

If the Over Load Probe LED lights up.

Check: that the power polarity has not been inverted, that no short-circuit is present, that the probes were not damaged during installation, that no excessive current absorption is present.

If the Over Load Battery LED lights up.

Check that the connection cables are not short-circuited, that the polarity has not been inverted, or that the battery is not damaged

- If the Open Line LED lights up.

Check that the connection cables, which connect the sensors are intact and that the signal wire is well connected. That the sensors are perfectly housed in their plinth, and that the end-of-line resistor is inserted and of the right Ohmic value.

- If the Closed Line LED lights up.

Check that the connection cables, which connect the sensors are intact and that the signal wire is well connected. That the sensors are perfectly housed in their plinth, and that the end-of-line resistor is inserted and of the right Ohmic value.

If the Control Unit is repeatedly issuing an alarm.

Check that there are no gas leaks. If the alarm signal and the FAULT indicator light turn on together, check the probes.

If the Control Unit is issuing an alarm and does not shut off the devices connected to it.

Check that the wiring is correct and that the jumper that carries power to the relay has been set properly. **All relays are free from electrical power.** Check the drawing of the connections.

If a 12Vdc solenoid for valve, which does not work well, is connected to the BX449F.

Direct connection of 12Vdc solenoid valves or sirens to the **BX449F** is not permitted.

An external power unit must always be used.

The **BX449F** gives a **max** current of **100mA**.

If other problems arise, a specialised and/or authorised technician and/or the Distributor of **BEINAT S.r.l.** should be contacted directly.

INSURANCE. This device is insured by the SOCIETÀ REALE MUTUA for the PRODUCT'S GENERAL LIABILITY up to a maximum of 1,500,000.00 EURO against damages caused by the device in case of failures in functioning.

WARRANTY. The warranty term is 3 years from manufacturing date, in agreement with the following conditions. The components acknowledged as faulty will be replaced free of charge, excluding the replacement of plastic or aluminium cases, bags, packing, batteries and technical reports.

The device must arrive free of shipment charges to **BEINAT S.r.l.**

Defects caused by unauthorized personnel tampering, incorrect installation and negligence resulting from phenomena outside normal functioning shall be excluded from the warranty.

BEINAT S.r.l. is not liable for possible damage, direct or indirect, to people, animals, or things; from product faults and from its enforced suspension of use.



DISPOSAL OF OLD ELECTRICAL & ELECTRONIC EQUIPMENT.

This symbol on the product or its packaging to indicates that this product shall not be treated as household waste. Instead, it shall be handed over to the applicable collection point for the recycling of electrical and electronic equipment, such as for example:

- sales points, in case you buy a new and similar product
- local collection points (waste collection center, local recycling center, etc.)

By ensuring this product is disposed of correctly, you will help prevent potential negative consequence for the environment and human health, which could otherwise be caused by inappropriate waste handling of this product. The recycling of materials will help to conserve natural resources. For more detailed information about recycling of this product, please contact your local city office, your household waste disposal service or the shop where you purchased the product.

Attention: in some countries of the European Union, the product is not included in the field of application of the National Law that applies the European Directive 2002/96/EC and therefore these countries have no obligation to carry out a separate collection at the "end of life" of the product.



IP20

Made in Italy

Control Unit **BX449F**

Lo styling è della b & b design

Dealer stamp

Purchase date:

Serial number:

Beinat S.r.l. following the purpose of improving its products, it reserves the right to modify the technical, aesthetic and functional characteristics at any time and without giving any notice.

BEINAT S.r.l.

Via Fatebenefratelli 122/C 10077, S. Maurizio C/se (TO) - ITALY

Tel. 011.921.04.84 - Fax 011.921.14.77

[http:// www.beinat.com](http://www.beinat.com)



Business - info@beinat.com

Technical support - laboratorio@beinat.com