

Fire Control Unit 4 Zone max 20 Detectors **BX44F** V.2



The new **BX44F** is born from the elegance and prestige that has always distinguished **BEINAT S.r.l.** and from the home fitness concept. The device has the capacity of controlling, through its connected probes, the presence of: " fire". Thanks to its innovative technology advances, the control unit is suitable to: civil use, industrial use and car parks.

Fire detection

To the **BX44F** you can connect up to 6 fire probes per each zone, either temperature or optical smoke detectors, through a balanced line.

The control unit's microprocessor checks the detectors and connection line efficiency, open or short-circuited.

When the probes detect a fire, they will switch the proper relay.

The **BX44F** is fitted with a TEST button to ease the system global check.

The Omega-type external structure, protection IP20, occupies 9 modules when installed on the panel gets the same protection of the panel itself.

In addition to the alarm signal light, it is fitted with an internal buzzer.





Important: Assembly / maintenance of the appliance must be carried out by qualified personnel and in accordance with applicable laws and regulations. The manufacturer assumes no responsibility for the use of products that have to comply with particular environmental and / or installation standards.



Important note

Before connecting the equipment, it is recommended that you read the instruction manual carefully and keep it for future reference. It is also recommended to perform the electrical connections correctly as per enclosed drawings, observing the instructions and the Standards.

N.B. Refer to the documentation in all cases where the symbol is on the side

 <p>Installation and user guide</p>	 <p>INSTALL IN SAFE AREA, NO ATEX</p>	<p>CONFORMITY</p>  <p>EN 45544-1-3 EN 50270 EN 54-2 EN 50130-4 EN 61010-1 Relación entregada de Eurofin Italia</p>
---	---	---

Main Specifications

CHECK the integrity of the unit after having removed it from the box.

Check that the data written on the box correspond to the type of gas used.

When doing the electrical connections, follow the drawing closely.

Any use of the detector for purposes other than the intended one is considered improper, and as a result of which **BEINAT S.r.l.** therefore disclaims any responsibility for possible damages caused to people, animals or objects.

IMPORTANT: Do not test the device using the gas tap as this does not necessarily provide sufficient concentration to activate the main alarm.

TERMS and EXPECTATIONS: The installation of the **BX44F** control unit, its ordinary and extraordinary maintenance, every six months, and its out of service removal at the end of the functional life guaranteed by the manufacturer, must be carried out by **authorized or specialized personnel**.

In order to achieve long and satisfactory use of your **BX44F** digital control unit, use it by respecting the following precautions.

Do not allow it to become wet.

The control unit can be seriously damaged as it is not waterproof either when immersed in water or exposed to high levels of humidity.

Do not drop it.

Heavy knocks or falls during transportation or installation can damage the appliance.

Avoid abrupt temperature fluctuations.

Sudden temperature variations can cause condensation and the control unit could work poorly.

Over a temperature of about +45°C, the monitor turns black. In such case it should cool down to become visible again.

Cleaning

Never clean the device with chemical products. If necessary, wash with a moist cloth.



Technical Specifications

Main power	230VAC 50/60Hz ±10%
Secondary Power Through Battery Max 2,2 Ah (Optional)	12 V  ±10%
Battery charger max. 2.2 Ah	Controlled
Power demand	8W max. 230V
Power demand5W max. @ 12 V
Range of the contacts on the fault relay	10A 250V resistive
Zones	4
Number of FIRE probes that can be connected	16 (4 per each zone)
Types of FIRE probes that can be connected. Optical smoke - fixed temperature - temperature rate of rise	
Micro-switches to include or exclude the probes	1 for each zone
Type of faults detected by fault circuit	Interruption, short circuit, or wear
Input signal FIRE.....	Max 5V.
Device accuracy	1% FS
Response time	< 2"
Control unit	Microprocessor
Functioning temperature	-10°C ÷ +60°C
Waiting, blinking period (warm-up)	About 2 minutes
Manual test	Built in
Max. distance between probes and unit	100 m
Cable diameter for connecting probes	1 mm ²
Omega-type size DIN EN 50092 9 modules	158*90*58
Connection: The cable of connection of the probe must not be installed together with the power cables. Otherwise, make sure to use a shielded cable	
Degree of protection	IP20

WARNING! Actions to be taken in case of alarm

- 1) Keep calm
- 2) Open the windows and ask for help
- 3) Do not turn on or off lights; do not use electrical apparatus
- 4) If possible push the nearest emergency button
- 5) If possible use the nearest fire-extinguisher. Be careful to not use water or foam based extinguishers near electrical apparatus or directly to electrical switchboard
- 6) In case of smoke or fire in a room, leave the danger zone directly, call the fire brigade, warn your neighbours and move immediately to the collecting point in the front of the house (main entrance and lawn).
- 7) If the fire is in another room and the smoke do not permit to use the stairs or the corridors, close firmly the doors and try to obstruct the apertures with wet clothes
- 8) If the smoke make your breathing difficult filter the air through a handkerchief (better if wet), lie on the floor (the smoke tend to rise)
- 9) If the alarm stops is necessary to locate the cause and take the appropriate action.



Components and Commands

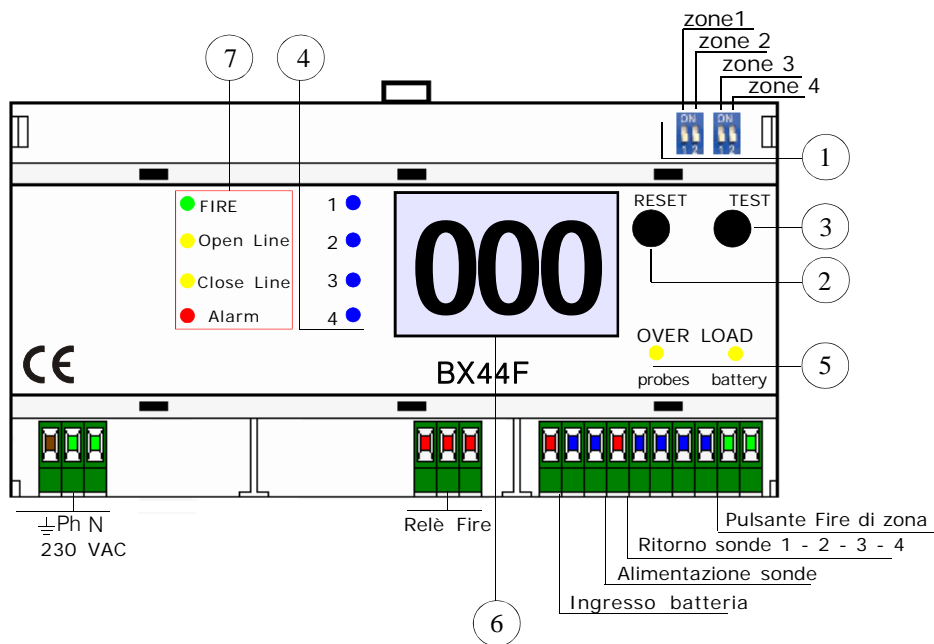

1) Group of 4 switches, one for each probe.

2) **RESET button:** This button is pressed to clear all memories, or to restore the control unit after a failure.

3) **TEST button:** Pressing and holding down this button, you can obtain a fire simulation. In order to perform this operation no failures or alarms should be present.

4) **PROBE LEDs:** Each LED represents a connected probe. These LEDs turn on cyclically or at each pass and indicate the connected probe on the display.

5) **OVER LOAD BATTERY and OVER LOAD PROBES LED.**

If the Battery LED turns on, it means the battery is not connected properly, or it has an anomalous voltage absorption.

If the Probes LED turns on, it means there is a short circuit or high current absorption in the probes.

6) **DISPLAY.** The display illustrated below has all segments on.

a) The battery icon will turn on when the **BX44F** is powered by an external battery.

The illustrated battery indicates also the external battery's charge status; when blinking it means the battery is running low.

b) The numbers "000" on the display indicate that there are no alarms. In case of alarm the writing "ALL" lights up and the zone led stops on the affected area.

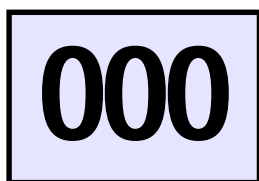

The display shows the fire probe not alarm

The display shows the probes FIRE in alarm

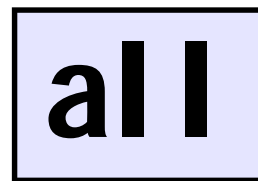

The display shows the line FIRE faulty open

The display shows the line FIRE faulty in short circuit

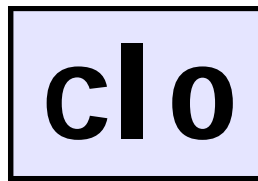

Electrical Connections - WARNING



Before connecting to the mains power, ensure the voltage is correct. Carefully follow the instructions and the connections according to Regulations in force, keeping in mind that **the signal cables should be laid separate from the power cables.** An automatic cut-off switch (appropriately identified as device sectioning of the detector) should be incorporated in the electrical system, adequately located and easily accessible.

PLEASE NOTE!
All relays are free of voltage

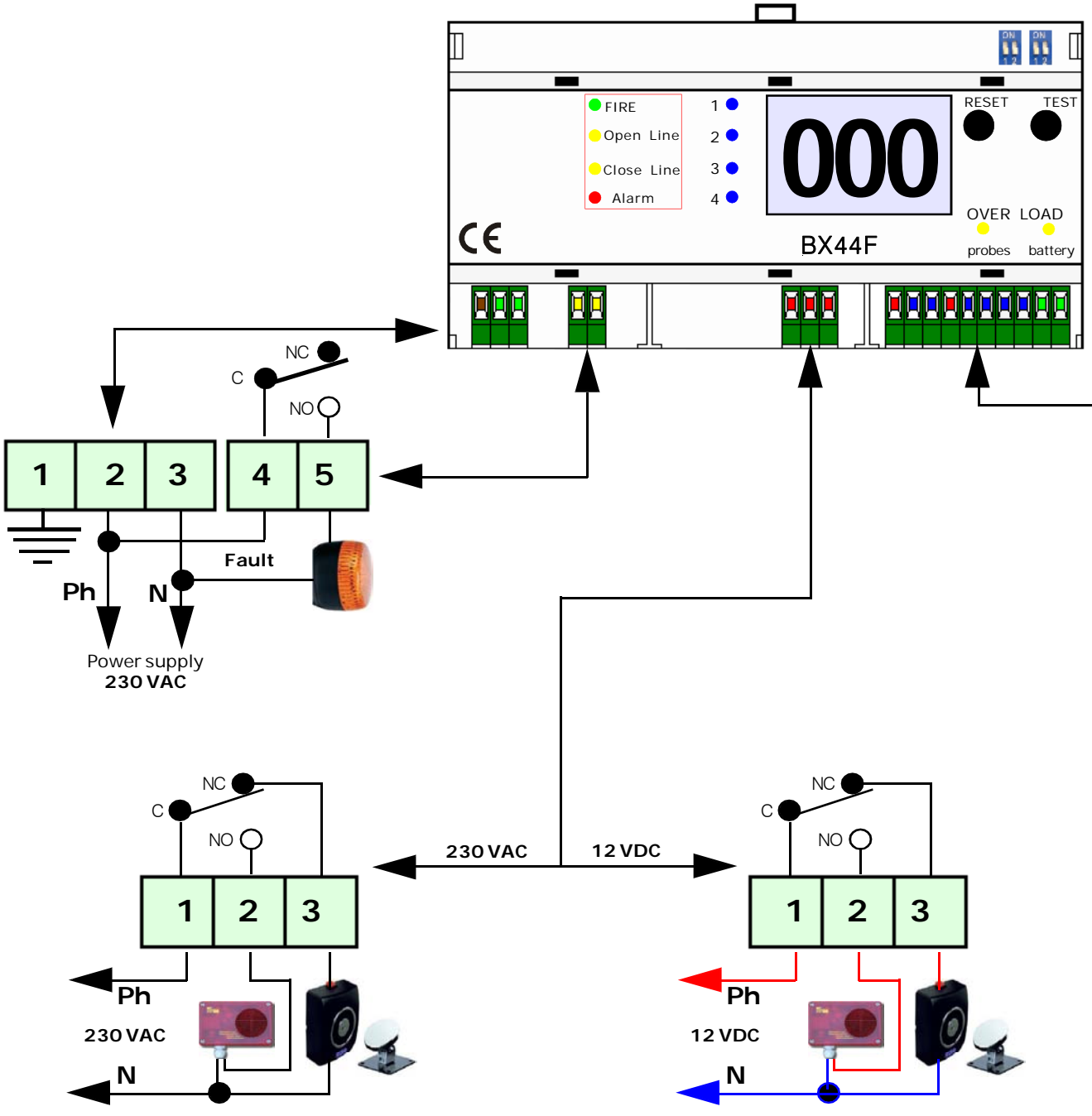

Connection of probes and eventual battery

PROBES Terminal block

In this diagram they are connected three probes GAS and one of fire.
N.B. at each input you can connect: 1 GAS probe
 1 Group probes fire from 1 to 5 max

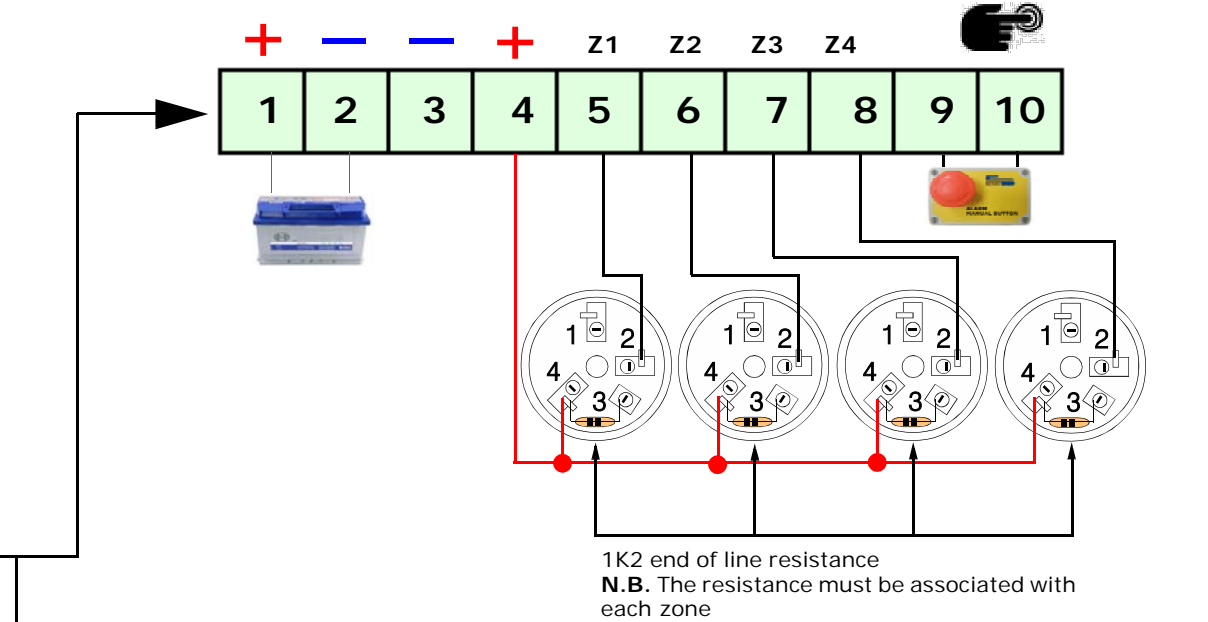

For each zone can be connected up to a maximum of 4 detectors (two are drawn on this drawing) in order to insert others continue with the same pattern.
N.B. Remember to insert the EOL resistor; Only at the last detector

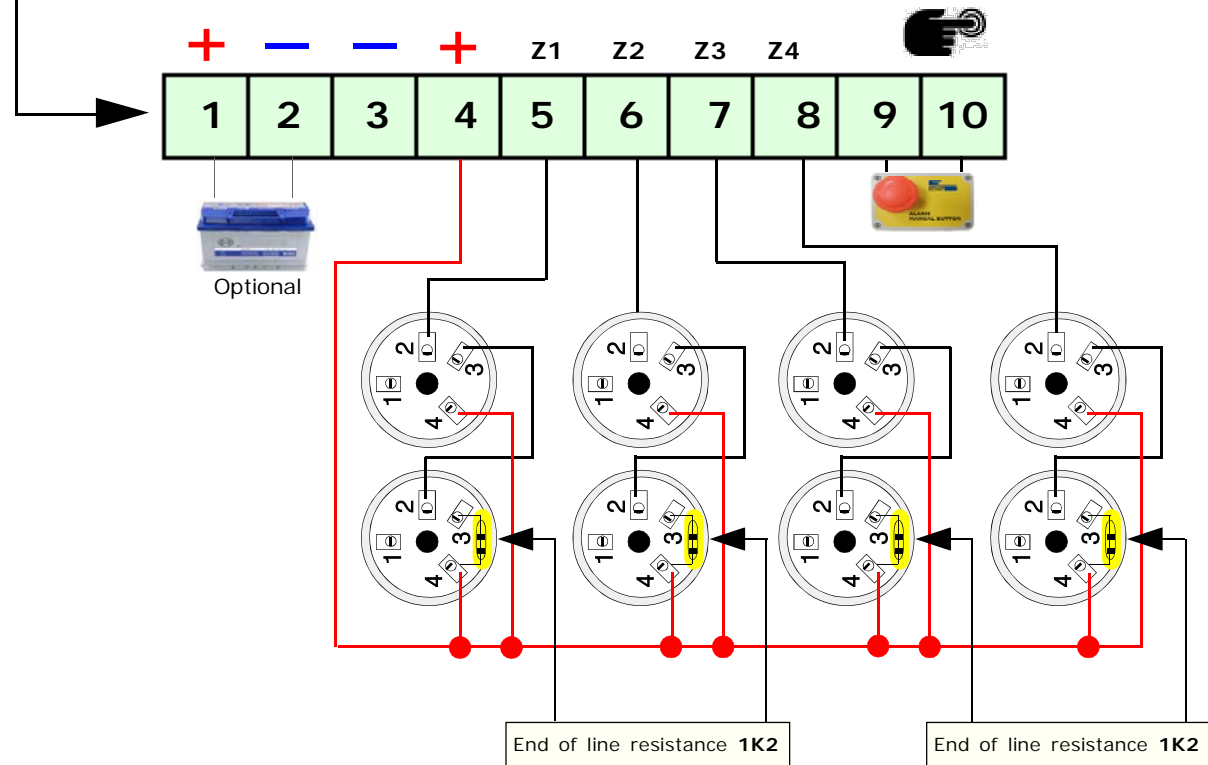

Zones Identification Leds

To the **BX44F** a row of LEDs has been adapted to indicate the active ZONES connected to it from n°.1 fino to n°.4.

In case of alarm:

The LED that represents the ZONE stops for about 15 seconds. This is done in order to identify the relevant zone or zones easily. Meanwhile, the writing "ALL" appears on the display. On the next pass, the LED (Zone) will be maintained again and the alarm will be issued.

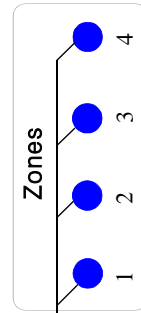

LEDs for identifying ZONES from n° 1 to n° 4

Installing, uninstalling or disabling the zones

Using the proper micro-switches on the **BX44F** you can enable or disable 4 ZONES. **Warning**, to each zone you can connect 4 fire probes.

Microswitches (1) to enable or disable the probes.
Position **ON** enabled - Position **OFF** disabled

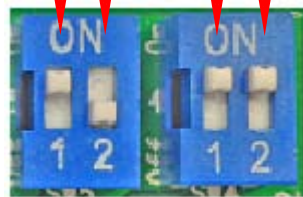

Switch zones 1 2 3 4

Omega-type size DIN EN 50092 9 modules

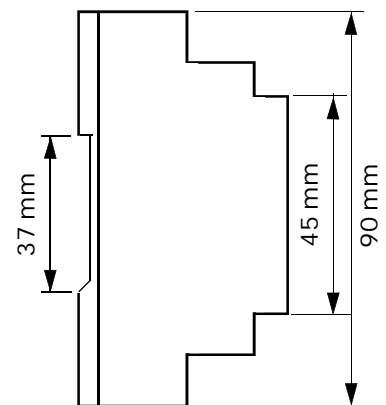
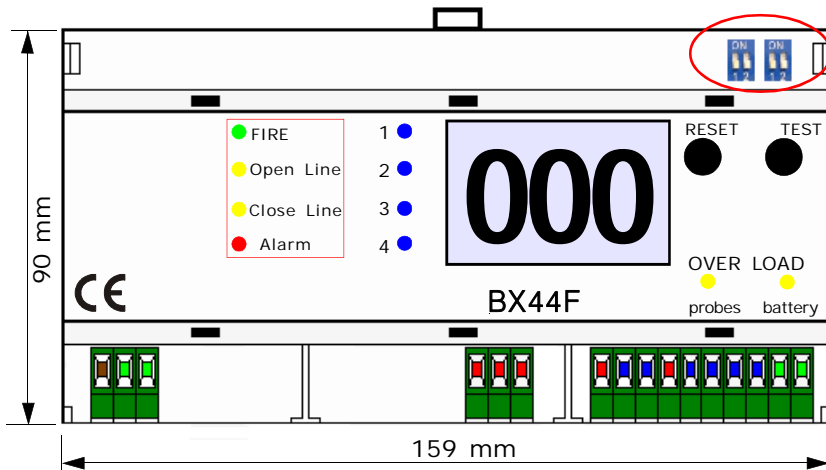

Main Compatible Probes

Even though all fires appear to be similar, each is characterized by a particular symptom: for example, paper and wood issue large quantities of white smoke, while burning rubber generates a high temperature increase and black smoke. Due to these remarkable differences, and taking into account the different sensors that can detect the different phenomena connected to fire, it is clear that the choice of the probe is the main element when building a correct security system.

BEINAT S.r.l recommends to follow the table below in order to associate each detection probe to the different fire symptoms. The table also indicates the recommended and acceptable positions.

Sensor	Effect detected	Recommended for	Suitable for	Not recommended
RF500	Optical smoke	Corridors, offices, lifts	Computer rooms damp rooms,	Bathrooms, kitchens, garage, biblioteche
RF570	Fixed temperature 70 C.	Thermal rooms Industrial kitchens	Kitchens, photocopying, bookstores, libraries	Greenhouses, saunas
RF540	Temperature increase	Means of transport	Computer rooms,libraries	
ZF300	Universal installation socket			
ZF350	Universal installation socket with Relay			

Measurements Range According the Heights of the ceiling

Another basic element of a correct fire system is its right dimensioning. Having a correctly sized system means selecting the ideal number of sensors for the monitored space.

In the **following drawing**, we will specify the maximum area that the different models can check when positioned at a **height of 4 meters**.

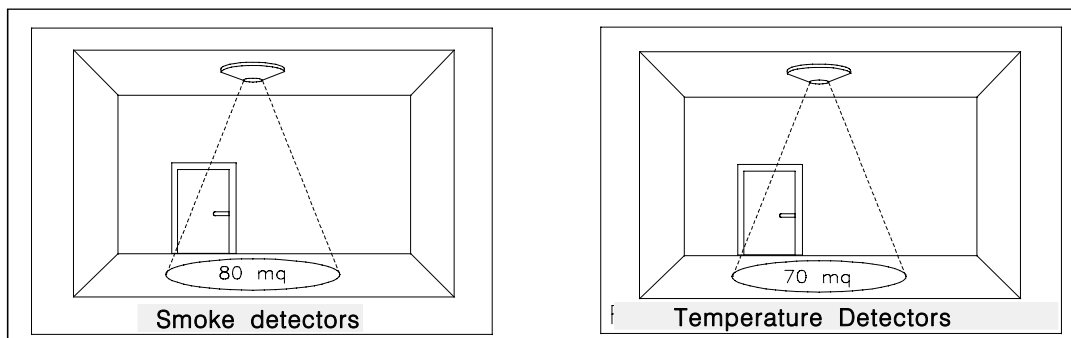

Before calling a technician, check...

If the device does not start up.

Check that the 230V mains power is correctly connected.

If powered by the battery, check that the 12Vdc power is correctly connected.

If the open line LED lights up.

Check that the connecting cables from the **BX44F** to the probes are intact, that the probes are properly powered, and that **the end of line resistance is plugged** and it has the right ohmic value.

If the close line LED lights up.

Check: that the power polarity has not been inverted, that no short-circuit is present, that the probes were not damaged during installation, and that **the end of line resistance is plugged** and it has the right ohmic value.

If the Over Load Battery LED lights up.

Check that the connection cables are not short-circuited, that the polarity has not been inverted, or that the battery is not damaged

If the Control Unit is issuing an alarm and does not shut off the devices connected to it.

Check that the wiring is correct and that the jumper that carries power to the relay has been set properly. **All**

NOTA: the relay is voltage free.



INSURANCE. This device is insured by the SOCIETÀ REALE MUTUA for the PRODUCT'S GENERAL LIABILITY up to a maximum of 1,500,000.00 EURO against damages caused by the device in case of failures in functioning.

WARRANTY. The warranty term is 3 years from manufacturing date, in agreement with the following conditions. The components acknowledged as faulty will be replaced free of charge, excluding the replacement of plastic or aluminium cases, bags, packing, batteries and technical reports.

The device must arrive free of shipment charges to **BEINAT S.r.l.**

Defects caused by unauthorized personnel tampering, incorrect installation and negligence resulting from phenomena outside normal functioning shall be excluded from the warranty.

BEINAT S.r.l. is not liable for possible damage, direct or indirect, to people, animals, or things; from product faults and from its enforced suspension of use.



DISPOSAL OF OLD ELECTRICAL & ELECTRONIC EQUIPMENT.

This symbol on the product or its packaging indicates that this product shall not be treated as household waste. Instead, it shall be handed over to the applicable collection point for the recycling of electrical and electronic equipment, such as for example:

- sales points, in case you buy a new and similar product
- local collection points (waste collection center, local recycling center, etc...).

By ensuring this product is disposed of correctly, you will help prevent potential negative consequence for the environment and human health, which could otherwise be caused by inappropriate waste handing of this product. The recycling of materials will help to conserve natural resources. For more detailed information about recycling of this product, please contact your local city office, your household waste disposal service or the shop where you purchased the product.

Attention: in some countries of the European Union, the product is not included in the field of application of the National Law that applies the European Directive 2002/96/EC and therefore these countries have no obligation to carry out a separate collection at the "end of life" of the product.



Control Unit **BX44F**

Lo styling è della b & b design

<input type="text"/>	Stamp and signature of the dealer
Registration number	<input type="text"/>

In agreement with its continuous development policy, we reserve the right to modify its products without notice.

BEINAT S.r.l. Via Fatebenefratelli 122/C
10077, S. Maurizio C/se (TO) - ITALY
Tel. 011.921.04.84 - Fax 011.921.14.77
[http:// www.beinat.com](http://www.beinat.com)



Business - info@beinat.com
Help Desk - laboratorio@beinat.com