

Household gas detector

RGX100 - v. 14

To protect your family

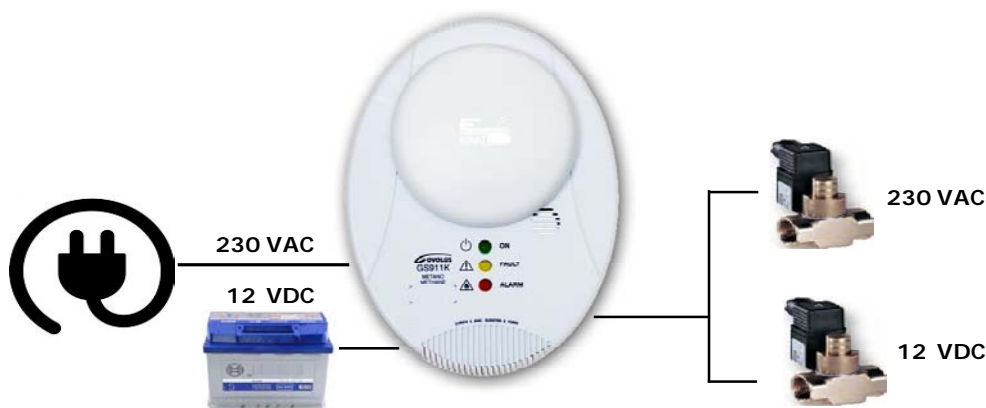

The elegance and the prestige, that have always made **BEINAT S.r.l** stand out from its competitors, together with the concept of home fitness comes the household gas detector **RGX100** detects through the **catalytic sensor**, the presence of explosive gas such as: Methane, LPG.

Gas detection

The detector is tested and calibrated to **10% of L.E.L.**

The power supply unit allows driving of a manual reset solenoid valve with a 12Vdc coil, without any buffer battery. If the voltage absorption is too high, you can later integrate a suitable backup battery. The battery is recharged automatically.

Through the built-in relay, the **RGX100** can activate: solenoid valves, sirens, and any other device alarm.

A series of technical features make this gas detector extremely versatile, reliable, accurate, and safe. through an internal jumper it is possible to select the relay impulse functioning, to connect manual reset solenoid valves, or the continuous functioning, to activate class "A" solenoid valves and sirens. The relay, free of voltage, allows installation of multiple detectors on a single solenoid valve ensuring control of multiple dangerous environments.

The detector is complete with a special **circuit that controls the catalytic sensor's efficiency level**, and signals any possible fault

These technical features make the detector ideal for the safety of civil environments according to EUROPEAN STANDARD.



Important: Assembly / maintenance of the appliance must be carried out by qualified personnel and in accordance with applicable laws and regulations.

The manufacturer assumes no responsibility for the use of products that have to comply with particular environmental and / or installation standards.



Important note

Before connecting the equipment, it is recommended that you read the instruction manual carefully and keep it for future reference. It is also recommended to perform the electrical connections correctly as per enclosed drawings, observing the instructions and the Standards.

N.B. Refer to the documentation in all cases where the symbol is on the side



**Installation and user
guide**

CONFORMITY



EN 50194
EN 50270
CEI 216-3
EN 61010-1

Installation EN 60079-29-2
Reports issued by TUV Italia

Precautions

CHECK the integrity of the probe after having removed it from the box.

Check that the data written on the box correspond to the type of gas used.

When doing the electrical connections, follow the drawing closely.

Any use of the detector for purposes other than the intended one is considered improper, and as a result of which **BEINAT S.r.l.** therefore disclaims any responsibility for possible damages caused to people, animals or objects.

INSTALLATION When performing the installation, please remind that if you pierce the **RGX100** container, it will lose its properties and its conformity to REGULATIONS.

TERMS and EXPECTATIONS: The installation of the **RGX100** detector, its ordinary and extraordinary maintenance, and its out of service removal at the end of the functional life guaranteed by the manufacturer, must be carried out by **authorized and/or specialized personnel**.

Do not allow it to become wet.

The detector can be seriously damaged when immersed in water. Remember that the probe has an IP42 protection degree..

Do not drop it.

Heavy knocks or falls during transportation or installation can damage the appliance.

Avoid abrupt temperature fluctuations.

Sudden temperature variations can cause condensation and the probe could work poorly.

Cleaning

Never clean the device with chemical products. If necessary, wash with a moist cloth.

Absolutely avoid using any cloth dipped in thinners, alcohol and chemical detergents.

Maintenance

The user periodically (every 6 months), it must carry out a verification of the detector functioning spraying a specific gas test into the slots on the front of the device until to get the alarm of the detector.

- At least 1 time a year perform a more accurate control by a specialized technician.
- The disposal of the detector (5 years after installation), It must be carried out by qualified technician

Technical Specifications

| | |
|--|--|
| Mains power | 230VAC 50/60 Hz +/- 10% |
| Battery power | 12 VDC – 1.2 Ah +/- 10% |
| Current consumption | 3.1 W @ 23□ |
| Range of relay contact switching | 10A 250V resistive - 5A 30Vdc resistive |
| Battery charger Max | Built in for a 1.2Ah 12VDC battery |
| Insulation | Class II |
| Explosive gas sensor | Catalytic |
| Explosive gas detector alarm threshold | At 10% of L.E.L. |
| Sensor's faults detected by Fault Circuit | Interruption, short circuit, or wear |
| Detection capsule end-of-life warning | After 5 years |
| Timed functioning solenoid valve only 12 V dc | Internal jumper |
| Continuous functioning solenoid valve or siren 230 V selection | Internal jumper |
| Audible and visual signal alarm by | LED diode and buzzer |
| Test phase duration | 60 seconds |
| Functioning temperature | -10°C to +40°C |
| Functioning humidity | 0÷90% RH non condensed |
| External degree of protection | IP42 |
| Mounting | External wall mount, or embedded box 503 |
| Body material | ABS self-extinguishing |
| Dimensions | 115x150x52 |

Functional Features Of Gas Sensors

The installation of the **RGX100** detector, its ordinary and extraordinary maintenance, and its out of service removal at the end of the functional life guaranteed by the manufacturer, must be carried out by authorized and/or specialized personnel.

The CATALYTIC technology sensor duration is guaranteed for 6 years (in clean air).

The detector's functioning temperature ranges from **-10°C to + 40°C**.

WARNING!

The CATALYTIC probe does not tolerate a gas detection exceeding **100% of L.E.L.**, with consequent natural death of the sensor.

Each immediate puff of gas that exceeds **100% of L.E.L.** takes away months of life from the sensor.

The detector must be tested by simulating the presence of gas by issuing it from a pre-calibrated testing aerosol.

A common cigarette lighter near the sensor does not guarantee excellent functioning.

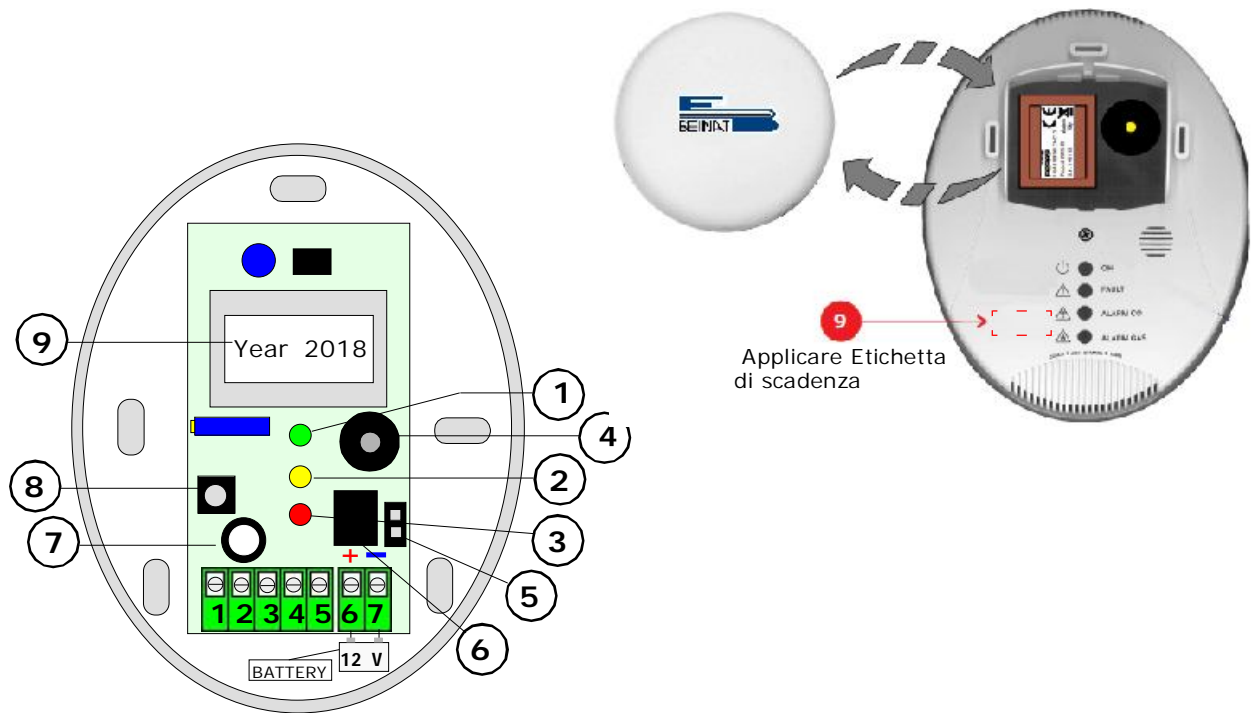

- 1) MAINS connected indication LED (ON).
- 2) FAULT indication LED. If this LED turns on, it means that the gas detection catalytic sensor is not working efficiently and must be replaced by an authorized service center.
- 3) ALARM indication LED. This LED turns on when room gas concentration exceeds the danger level.
- 4) BUZZER. This Buzzer sounds when the detector is in the main alarm condition.
- 5) Jumper to select the relay functioning mode.
By closing the two poles, the relay will be set to impulse functioning. When the alarm is triggered, the relay will close the C and NA contacts for about 90 seconds, and then will reopen them. This is needed to prevent damaging some types of manual reset solenoid valve coils.
This features is suitable only when a 12 Vdc electrovalve is connected.
By opening the two poles, the relay will be set to continuous functioning.
- 6) Relay. This relay changes its position when the detector trigger the main alarm.
- 7) Catalytic sensor for Methane or LPG explosive gas detection.
- 8) TEST button. This button is used to simulate a gas leak, after installation.
- 9) Identification label, registration number and manufacturing year, located under the ABS small dome.
9) Label of the gas sensor expiration date.
This label must be applied by the technician during the installation and remembering that the gas sensor **must be reviewed after 5 Years.**

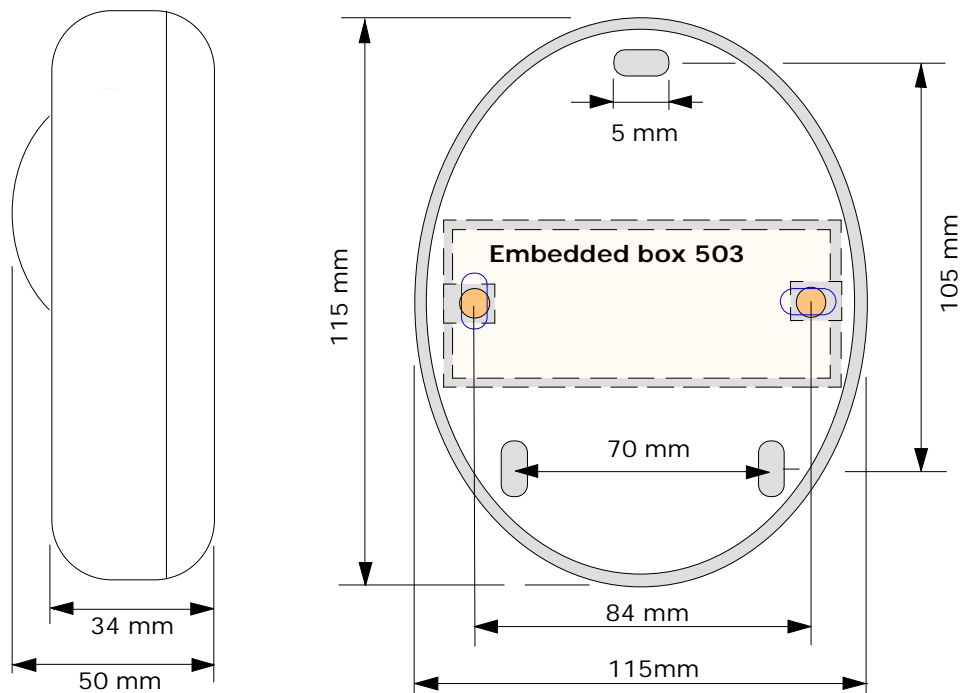

Electrical connections



WARNING

Before connecting to the mains power, ensure the voltage is correct. Carefully follow the instructions and the connections according to Regulations in force. An automatic disconnecting switch (appropriately identified as the detector sectioning device) must be incorporated in the electrical system, suitably located and easily accessible.

Diagram of the Detector RGX100

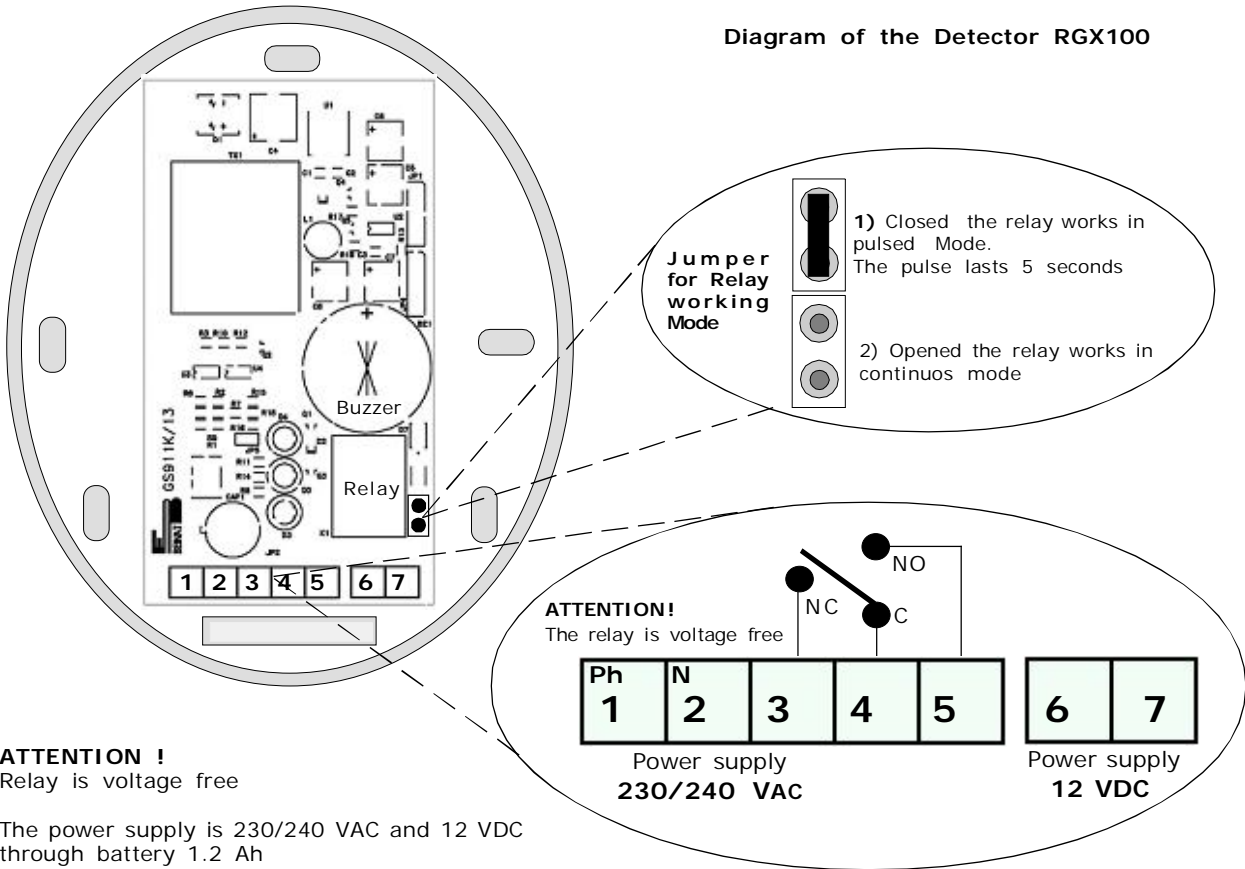

ATTENTION !
Relay is voltage free

The power supply is 230/240 VAC and 12 VDC through battery 1.2 Ah

Connection with a normally open solenoid valve 230VAC

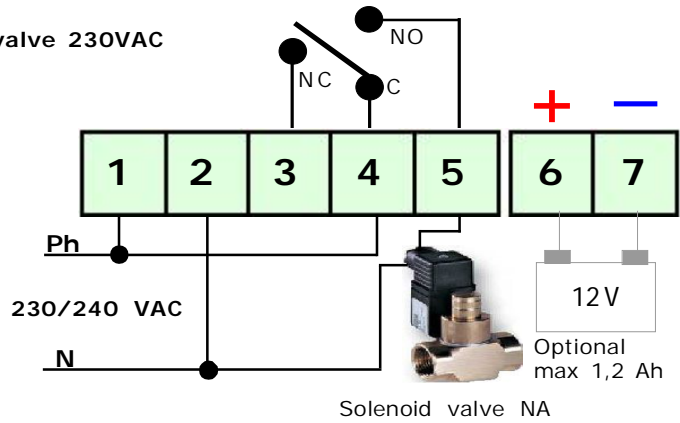

Connection with a normally closed solenoid valve 230VAC

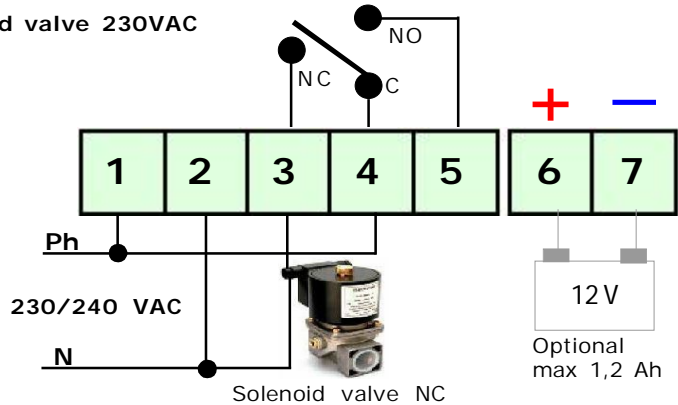

Electrical Connections

Normally open solenoid valve 12VDC

ATTENTION !

Relay is voltage free

The power supply is 230/240 VAC. with a buffer battery 12VDC 1.2Ah MAX

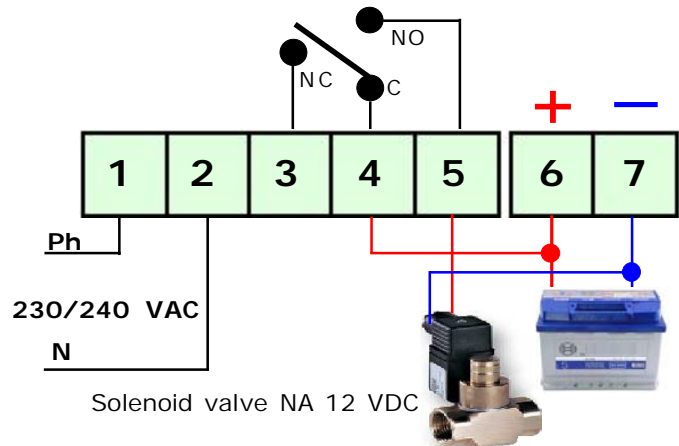

Normally open solenoid valve 12VDC

ATTENTION !

Relay is voltage free

The power supply is 230/240 VAC. with a buffer battery 12VDC - 1.2Ah MAX

N.B. The 12VDC voltage can be derived from another source.

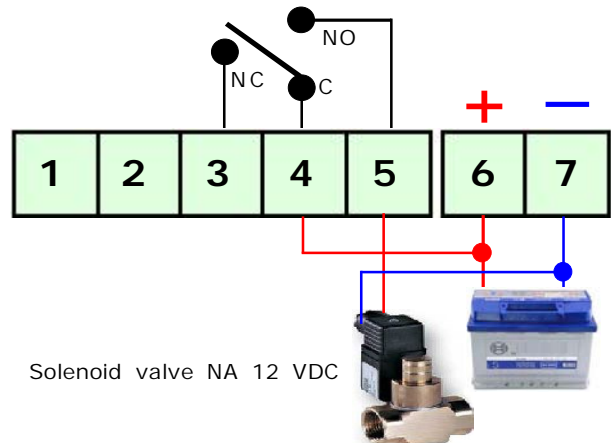

Connection with a normally closed solenoid valve 12 VDC

ATTENTION !

Relay is voltage free

The power supply is 230/240 VAC. with a buffer battery 12VDC 1.2Ah MAX

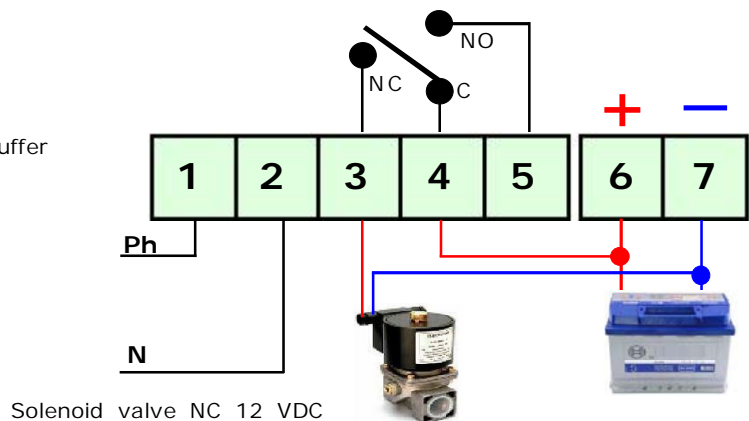

Installation measures and positioning

Currently national standards enforceable in the installation country covering the installation and use of gas powered equipment are to be respected, as are standards covering smoke dispersion and ventilation of enclosed areas, even though gas detection equipment is installed.

Essential element for the correct functioning of the detector is its correct installation.

Following the suggestions in this section you will get a high accuracy combined with a total absence of false alarms.

The **RGX100** is an equipment adapted to be mounted externally on a wall. Installing, it is fine to use ordinary care that requires an electronic device, and then:

- Install the detector away from sources of excessive heat.
- Avoid that liquids come into contact with the detector **RGX100**, remembering that its external structure has degree of protection **IP42**.

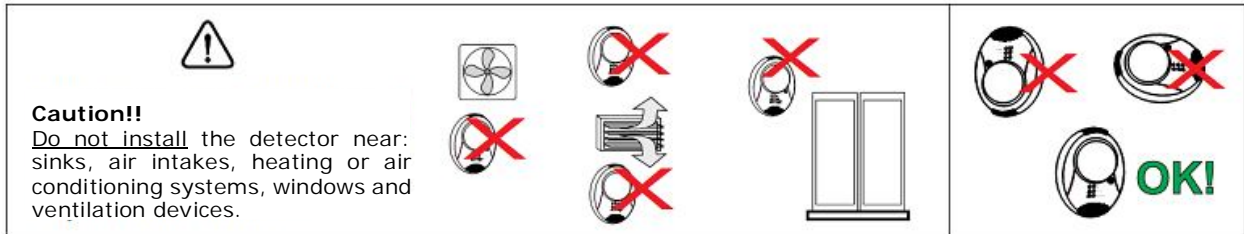

The detector should not be installed:

- in environments where the temperature drops below 10 ° C or rises above 40 ° C.

The detector is equipped to detect different types of gases, and according to these, its must to be positioned at different heights.

These heights are:

- **30 cm** from the lowest point of the floor in order to detect **heavy gases (LPG, etc)**
- **30 cm** from the highest point of the ceiling in order to detect **light gas (Methane etc)**
- **Install detectors from 1 to 4 m from gas appliances**

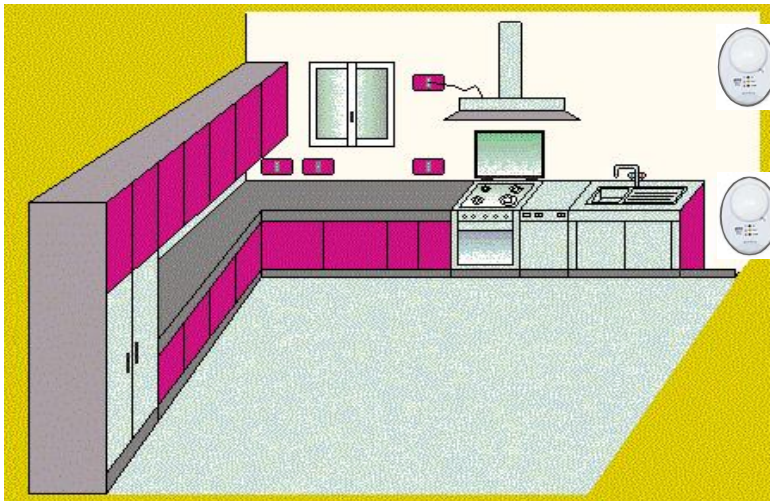

METHANE gas detector
max. 30 cm from the ceiling

LPG gas detector
max. 30 cm from the floor

The installation of the detector does not exempt from ... The compliance with all regulations concerning the characteristics, installation and use of gas appliances. The ventilation of the spaces and the elimination of combustion products are described in the **UNI norms according to ART. 3 LAW 1083 / 71** and relevant legal provisions.

Turn on and testing

1) By providing the proper voltage with an external switch, which must be provided with safety fuses, you will see that the **POWER LED**, wait 60 seconds, after this time the detector is ready to detect.

2) Pressing the TEST button, you get the simulation of a gas leak and the detector performs the following actions: The **LED ALARM** will turn on and the relay will change its working state after 5 seconds. Ceased the alarm, the LED will turn off, it will stop the buzzer sound and the connected devices will be disabled.

* To complete the general test, emit gas from a calibration bottle pre-calibrated within 20% of the LEL.

Do a test with a common cigarette lighter could cause damage to the sensor.

We recommend that you make this test at least once a year.

Before calling a technician ...

- If the device does not start up.

Check that the 230/240 VAC power is correctly connected.

When the fault LED lights up

Check the capsule detector, the **RGX100** may have failed.

It may be exhausted: after 5/6 years should be replaced.

If the detector goes into alarm repeatedly.

Check that there are no gas leaks. Check that together with the alarm does not turn on even the led **FAULT**, in this case, proceed with the inspection of the capsule detector.

If the detector goes into alarm and closes the connected equipment.

Check that connections are correct and that the jumper which leads to the common voltage of the relay has been carried out, **all the relays are voltage free**. Check the scheme of connection.

If RGX100 is connected to a Solenoid valves 12 VDC and does not work.

To **RGX100** you can not connect directly solenoid valves, sirens in 12 VDC. It must always to use to an external supply.

Do not tamper with the detector

In order not to cause decalibration of the device and electric shock.

If other problems arise, it is necessary to call a specialised and/or authorised technician and/or the **Distributor** of **BEINAT S.r.l.** should be contacted directly.

WARNING! Actions to be taken in case of alarm

- 1) Put out all free flames.
- 2) Close the main gas tap or the LPG cylinder tap.
- 3) Do not turn any lights on or off; do not turn on any electrical device or appliance.
- 4) Open windows and doors in order to increase ventilation.

If the alarm stops, its cause must be found and the relevant consequent measures taken.

If the alarm continues and the cause of gas presence cannot be found or removed, abandon the building and call the emergency services when outside (fire department, distributors, etc.)

Warning !!

If you have the following symptoms: vomiting, sleepiness, or else, go to the closest first aid station and inform the operators that you could have been poisoned by **Gas Methane or LPG**.



INSURANCE. This device is insured by the SOCIETÀ REALE MUTUA for the PRODUCT'S GENERAL LIABILITY up to a maximum of 1,500,000.00 EURO against damages caused by the device in case of failures in functioning.

WARRANTY. The warranty term is 3 years from manufacturing date, in agreement with the following conditions. The components acknowledged as faulty will be replaced free of charge, excluding the replacement of plastic or aluminium cases, bags, packing, batteries and technical reports.

The device must arrive free of shipment charges to **BEINAT S.r.l.**

Defects caused by unauthorized personnel tampering, incorrect installation and negligence resulting from phenomena outside normal functioning shall be excluded from the warranty.

BEINAT S.r.l. is not liable for possible damage, direct or indirect, to people, animals, or things; from product faults and from its enforced suspension of use.

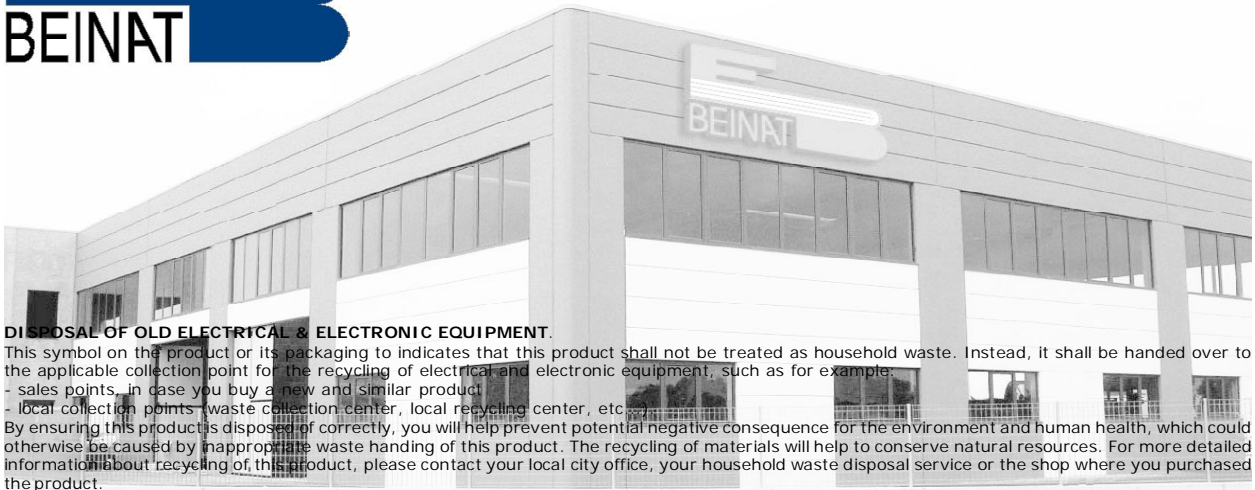

DISPOSAL OF OLD ELECTRICAL & ELECTRONIC EQUIPMENT.

This symbol on the product or its packaging to indicates that this product shall not be treated as household waste. Instead, it shall be handed over to the applicable collection point for the recycling of electrical and electronic equipment, such as for example:

- sales points, in case you buy a new and similar product
- local collection points (waste collection center, local recycling center, etc.)

By ensuring this product is disposed of correctly, you will help prevent potential negative consequence for the environment and human health, which could otherwise be caused by inappropriate waste handing of this product. The recycling of materials will help to conserve natural resources. For more detailed information about recycling of this product, please contact your local city office, your household waste disposal service or the shop where you purchased the product.

Attention: in some countries of the European Union, the product is not included in the field of application of the National Law that applies the European Directive 2002/96/EC and therefore these countries have no obligation to carry out a separate collection at the "end of life" of the product.



Detector RGX100 *Lo styling è della b & b design*

Dealer Stamp

Purchase Date:

Registration Number :

Beinat S.r.l. following the targhet to improve its products, reserves the right to modify the technical features, aesthetic and functional any time without prior notice..

BEINAT S.r.l.
Via Fatebenefratelli 122/C 10077, S. Maurizio C/se (TO) - ITALY
Tel. 011.921.04.84 - Fax 011.921.14.77
[http:// www.beinat.com](http://www.beinat.com)

