

Switching power supply ASI012

Rev. 1

Indispensable power supply for the **addressed** system

The switching power supply **ASI012** is born to complete the **addressed** gas leak detection system this power supply is used to provide a 15VDC electrical voltage to feed 8 gas sensors
A series of courtesy terminals have been added for a possible **RS-485 MODBUS** Network connection.

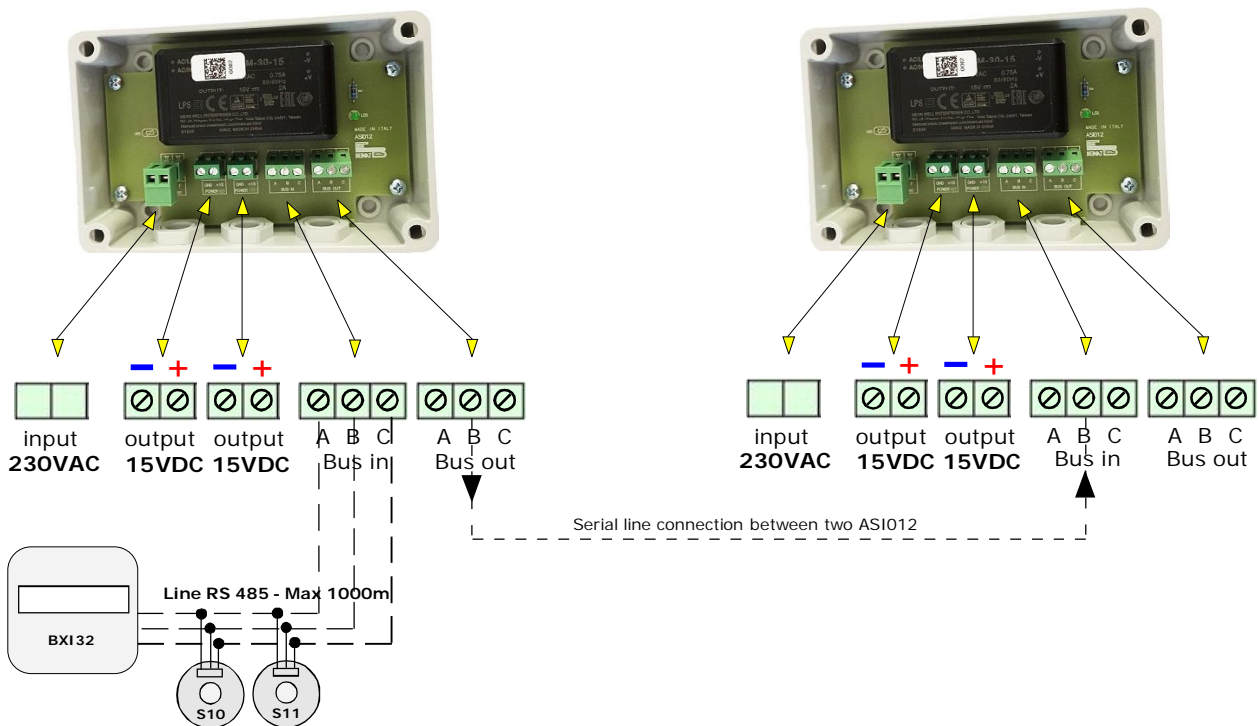

Installation and user guide

Switching power supply technical features
ASI012110÷230 VAC - 12 VDC - 30 Wat

Power supply for **8 sensors**

Note: each sensor absorbs 200 mA
INSTALL IN SAFE AREA, NO ATEX

Note. Before connecting the equipment, it is recommended that you read the instruction manual carefully and keep it for future reference.
It is also recommended to perform the electrical connections correctly as per enclosed drawings, observing the instructions and the Standards.



INSURANCE. This device is insured by the SOCIETÀ REALE MUTUA for the PRODUCT'S GENERAL LIABILITY up to a maximum of 1,500,000.00 EURO against damages caused by the device in case of failures in functioning.

WARRANTY. The warranty term is 3 years from manufacturing date, in agreement with the following conditions. The components acknowledged as faulty will be replaced free of charge, excluding the replacement of plastic or aluminium cases, bags, packing, batteries and technical reports.

The device must arrive free of shipment charges to **BEINAT S.r.l.**

Defects caused by unauthorized personnel tampering, incorrect installation and negligence resulting from phenomena outside normal functioning shall be excluded from the warranty.

BEINAT S.r.l. is not liable for possible damage, direct or indirect, to people, animals, or things; from product faults and from its enforced suspension of use.



DISPOSAL OF OLD ELECTRICAL & ELECTRONIC EQUIPMENT.

This symbol on the product or its packaging to indicates that this product shall not be treated as household waste. Instead, it shall be handed over to the applicable collection point for the recycling of electrical and electronic equipment, such as for example:

- sales points, in case you buy a new and similar product
- local collection points (waste collection center, local recycling center, etc...).

By ensuring this product is disposed of correctly, you will help prevent potential negative consequence for the environment and human health, which could otherwise be caused by inappropriate waste handling of this product. The recycling of materials will help to conserve natural resources. For more detailed information about recycling of this product, please contact your local city office, your household waste disposal service or the shop where you purchased the product.

Attention: in some countries of the European Union, the product is not included in the field of application of the National Law that applies the European Directive 2002/96/EC and therefore these countries have no obligation to carry out a separate collection at the "end of life" of the product.

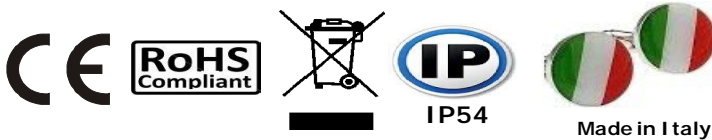

Power supply ASI012 *Lo styling è della b & b design*

Stamp and signature of the dealer

Purchase date:

Serial Number :

The Beinat S.r.l. following the targhet to improve its products, reserves the right to modify the technical features, aesthetic and functional any time without prior notice.

BEINAT S.r.l. Via Fatebenefratelli 122/C
10077, S. Maurizio C/se (TO) - ITALY
Tel. 011.921.04.84 - Fax 011.921.14.77
[http:// www.beinat.com](http://www.beinat.com)

 **Business** - info@beinat.com
Help Desk - laboratorio@beinat.com